

## REGULATING GROUP WITH THERMOSTATIC MIXING VALVE DN 25

### Description

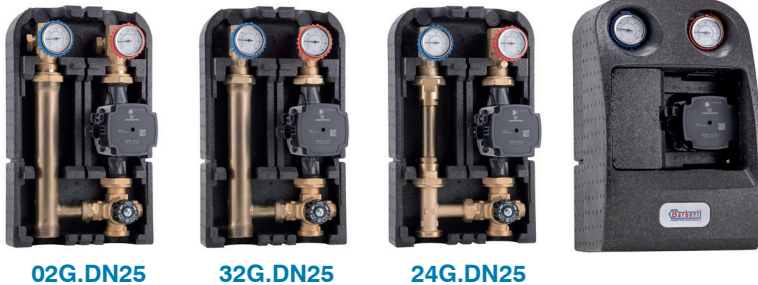

Preassembled pump group for fixed point regulation and circulation of mixed fluid. Allows the circulation of the thermal fluid, coming from the primary circuit, by keeping the temperature at a pre-set value (fixed point) through the help of a mixing valve with thermostatic element. It is used in heating systems in general and radiant panel systems. The group is composed of a pump, flow/return shut-off valves, thermostatic mixing valve, flow/return temperature gauges, anti-thermosiphon check valve, thermal insulation. The 02G.DN25 series is fitted for the installation of a

differential by-pass valve, while in the 32G.DN25 and 24G.DN25 series the differential by-pass valve can be installed only externally. The 24G.DN25 series is fitted for the installation of a 110 or 130 mm energy metering device. All the groups are reversible (the flow line can be exchanged with the return line).

### Range of products

**BAFA**  
L I S T

Regulating group with thermostatic mixing valve	XXX	XXX	XX	X	X
Group with connections for by-pass, system side connections G 1 F	02G	025			
Group without connections for by-pass, system side connections G 1 F	32G	025			
Group fitted for energy meter (G 3/4 110 mm, G 1 130 mm), without connections for by-pass, system side connections G 1 F	24G	025			
Without accessories			00		
With fittings 44D.DN25 (G 1 F-G 1 1/2 RN)			01		
Without pump				X	
Pump Grundfos UPM3 AUTO 25-70 180				U	
Pump Wilo Para 25-180/7-50/SC-12				H	
Pump Grundfos UPML AUTO 25-105 180				K	
Pump Grundfos UPSO 25-65 180 (Extra EU)				C	
Temperature adjustment range 30–60 °C					-
Temperature adjustment range 25–50 °C					E

### Features

Working temperature range: **5–90 °C**

Max working pressure: **10 bar**

Female connections: **EN 10226-1**

Male connections: **ISO 228-1**

Connection centre distance: **125 mm**

Pump: **Grundfos UPM3 AUTO 25-70 180**

**Wilo Para 25-180/7-50/SC-12**

**Grundfos UPML AUTO 25-105 180**

**Grundfos UPSO 25-65 180 (Extra EU)**

Suitable fluids: **water, glycol solutions (max 30%)**

Temperature adjustment range: **25–50 and 30–60 °C**

Factory setting: **38 and 45 °C**

Temperature gauge scale: **0–120 °C**

### Materials

Ball valves

- Body: **brass EN12165 CW617N**
- Gaskets: **PTFE, EPDM, Viton**

Thermostatic mixing valve

- Body: **brass EN 1982 CB753S**
- Fittings: **brass EN 12164 CW614N**
- Plug and nut: **brass EN 12165 CW617N**
- Gaskets: **EPDM, asbestos free fiber**
- Spring: **stainless steel AISI 302**

Extension: **galvanized steel**

T-joint (24G.DN25 groups): **brass EN12165 CW617N**

Check valve insert

- Body and obturator: **POM**
- Gasket: **NBR**

Pump

- Body: **cast iron**
  - Electric supply: **230 V-50/60 Hz**
  - Protection class:
    - Grundfos UPM3: **IP 44**
    - Wilo Para: **IPx4D**
    - Grundfos UPML: **IPx2D**
    - Grundfos UPSO (Extra EU): **IP 44**
  - Centre distance: **180 mm**
  - Connections: **G 1 1/2 M (ISO 228-1)**
- Insulation shell
- Body: **EPP**
  - Density: **60 kg/m<sup>3</sup>**
  - Working temperature range: **-5–120 °C**
  - Thermal conductivity: **0,04 W/(m·K)**

Components

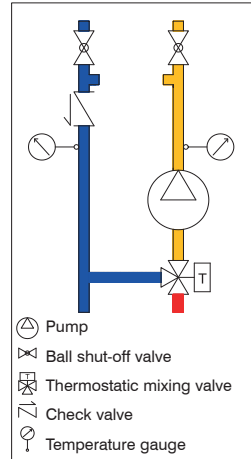
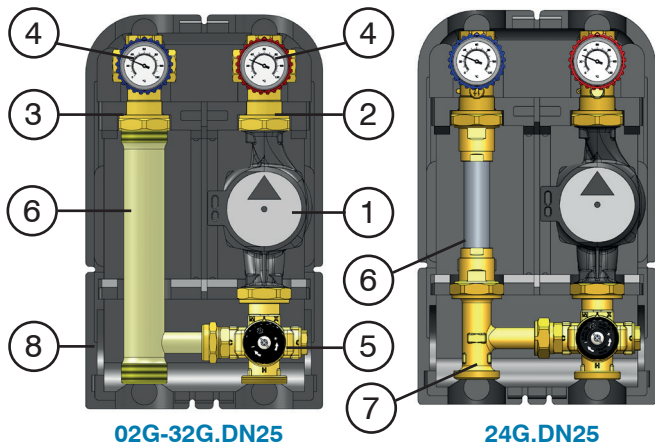

02G.DN25-32G.DN25-24G.DN25		
1	Pump	Grundfos UPM3 AUTO, Wilo Para, Grundfos UPML AUTO, Grundfos UPSO (Extra EU)
2	Ball shut-off valve	
3	Ball shut-off valve with check valve	
4	Temperature gauge	
5	Thermostatic mixing valve	
6	Extension/Extension for energy metering in groups 24G.DN25	
7	T-joint (only in 24G.DN25 groups)	
8	Insulation	

Dimensions

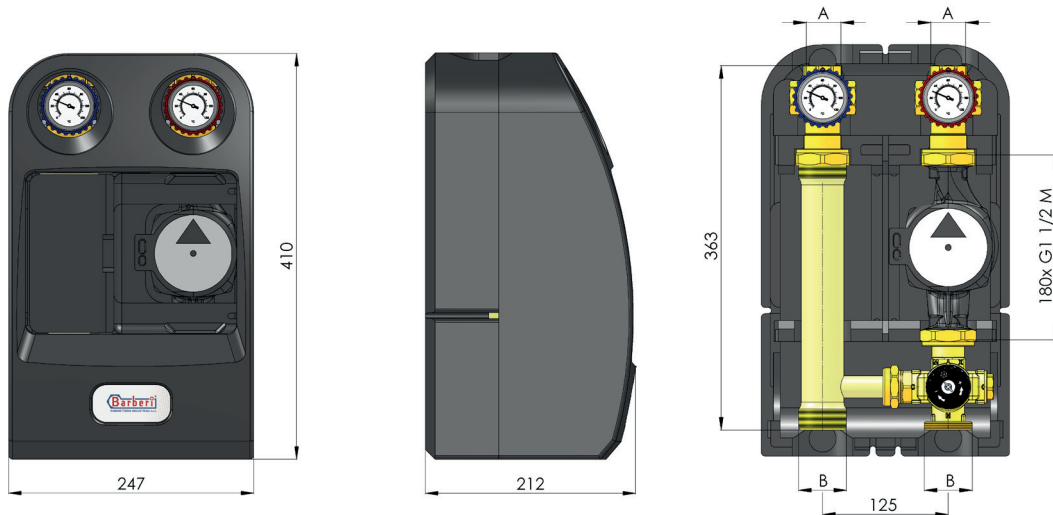

Code	P [bar]	A	B	Pump	Weight [kg]	N. P/B	N. P/C
02G 025 00X (E)	10	G 1 F	G 1 1/2 M	Without pump	4,05	-	1
02G 025 00U (E)	10	G 1 F	G 1 1/2 M	Grundfos UPM3 AUTO 25-70 180	5,84	-	1
02G 025 00H (E)	10	G 1 F	G 1 1/2 M	Wilo Para 25-180/7-50/SC-12	5,64	-	1
02G 025 00K (E)	10	G 1 F	G 1 1/2 M	Grundfos UPML AUTO 25-105 180	6,39	-	1
02G 025 00C (E)	10	G 1 F	G 1 1/2 M	Grundfos UPSO 25-65 180 (Extra EU)	6,7	-	1
32G 025 00X (E)	10	G 1 F	G 1 1/2 M	Without pump	4,05	-	1
32G 025 00U (E)	10	G 1 F	G 1 1/2 M	Grundfos UPM3 AUTO 25-70 180	5,84	-	1
32G 025 00H (E)	10	G 1 F	G 1 1/2 M	Wilo Para 25-180/7-50/SC-12	5,64	-	1
32G 025 00K (E)	10	G 1 F	G 1 1/2 M	Grundfos UPML AUTO 25-105 180	6,39	-	1
32G 025 00C (E)	10	G 1 F	G 1 1/2 M	Grundfos UPSO 25-65 180 (Extra EU)	6,7	-	1
24G 025 00X (E)	10	G 1 F	G 1 1/2 M	Without pump	4,05	-	1
24G 025 00U (E)	10	G 1 F	G 1 1/2 M	Grundfos UPM3 AUTO 25-70 180	5,84	-	1
24G 025 00H (E)	10	G 1 F	G 1 1/2 M	Wilo Para 25-180/7-50/SC-12	5,64	-	1
24G 025 00K (E)	10	G 1 F	G 1 1/2 M	Grundfos UPML AUTO 25-105 180	6,39	-	1
24G 025 00C (E)	10	G 1 F	G 1 1/2 M	Grundfos UPSO 25-65 180 (Extra EU)	6,7	-	1

N. P/B: number of pieces in box - N. P/C: number of pieces in carton  
Other pump types should be evaluated

Diagrams

**Group sizing** (operation for specialized/authorized technical personnel).

**Step 1: head losses of the group without pump.** Enter on the x-axis of the first diagram with the design flow rate value. Cross the curve of the group and read the corresponding head losses of the group (without pump) on the y-axis.

**Step 2: available head of the pump.** With the same design flow rate value, enter on the x-axis of the selected pump diagram ("Head of pump"). Cross the curve of the selected working mode (Constant speed, Proportional pressure, Constant pressure) and read the corresponding available head of the pump on the y-axis.

**Step 3: pump validation.** Calculate the difference between the available head of the pump and the head losses of the group without pump. The remaining pump head should be higher than the head losses of the rest of the system: if so, the selected pump is suitable to supply water to the rest of the system, otherwise a different pump working mode or pump size or different group size or a system resizing could be necessary.

**Hydraulic characteristics: head losses of the thermostatic regulating group without pump**

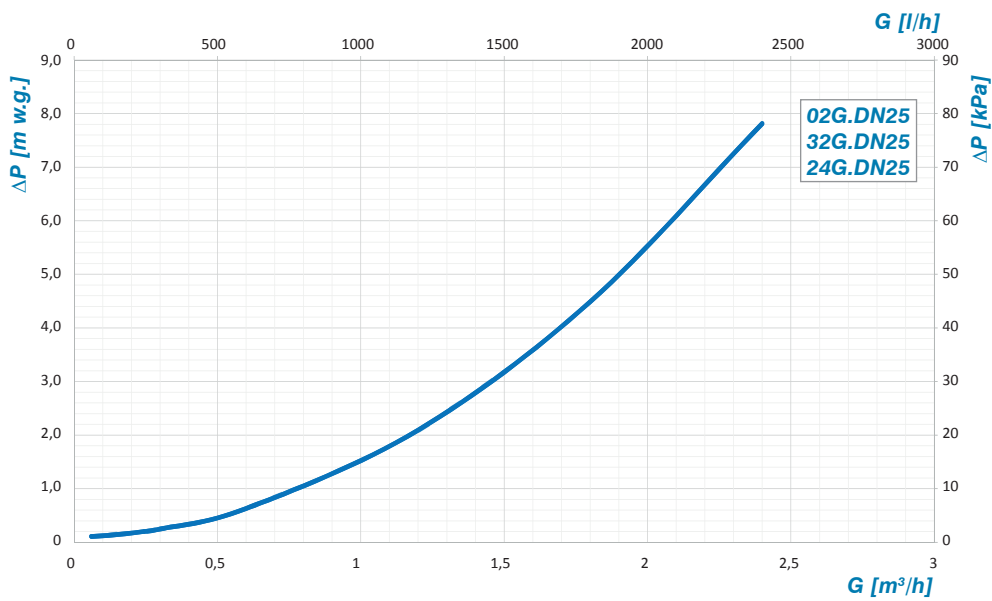

**Head and power consumption of the pumps**

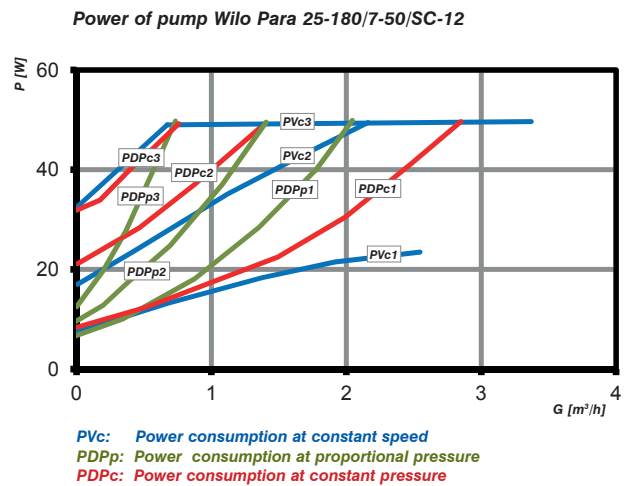
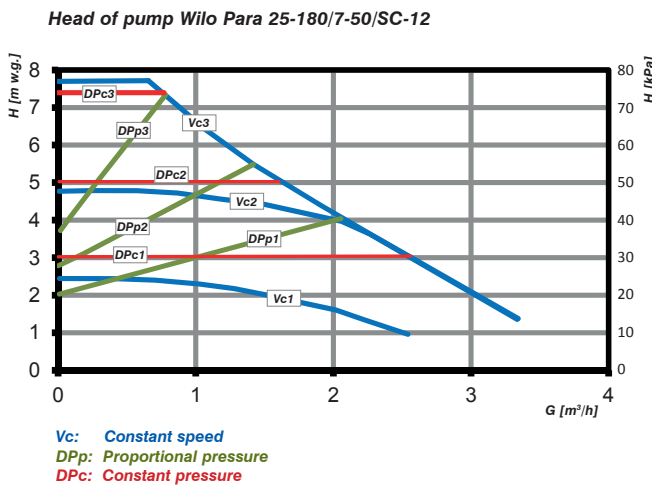

Head of pump Grundfos UPM3 AUTO 25-70 180

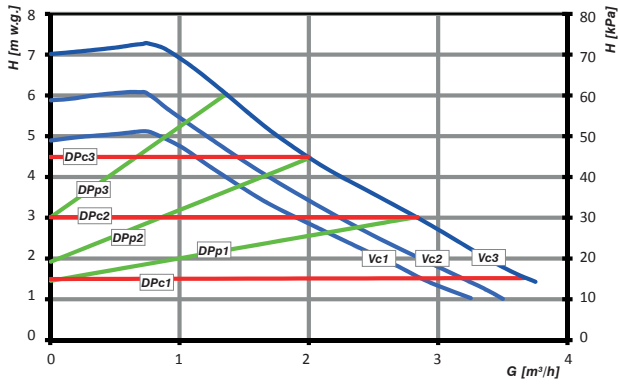

Vc: Constant speed  
 Dpp: Proportional pressure  
 DPc: Constant pressure

Power of pump Grundfos UPM3 AUTO 25-70 180

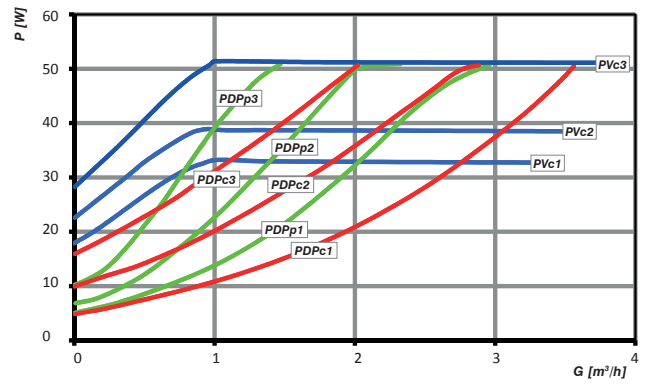

Pvc: Power consumption at constant speed  
 PDPp: Power consumption at proportional pressure  
 PDPc: Power consumption at constant pressure

Head of pump Grundfos UPML AUTO 25-105 180

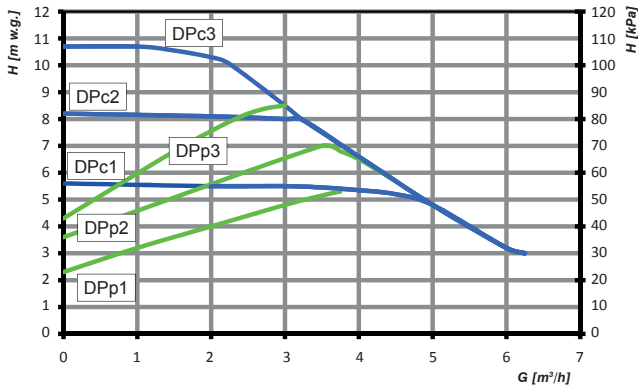

Dpp: Proportional pressure  
 DPc: Constant pressure

Power of pump Grundfos UPML AUTO 25-105 180

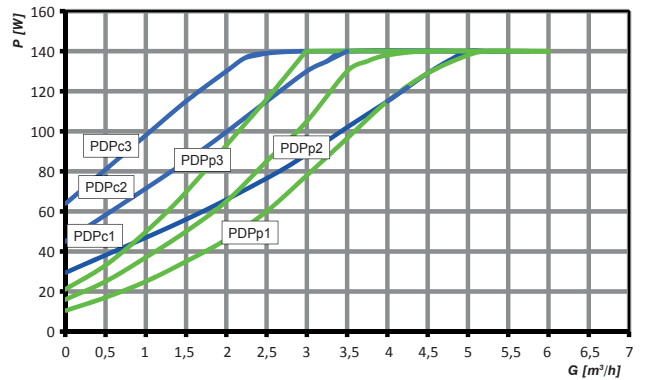

PDPp: Power consumption at proportional pressure  
 PDPc: Power consumption at constant pressure

Head of pump Grundfos UPSO 25-65 180 (Extra EU)

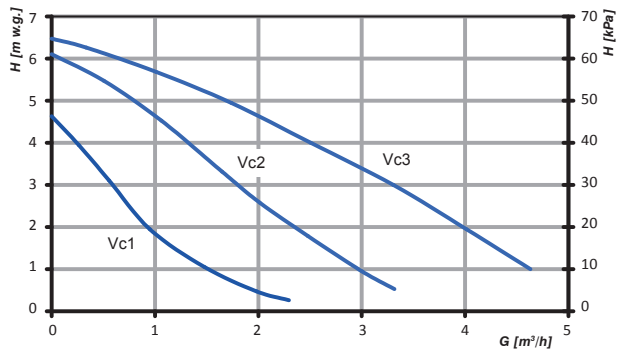

Vc: Constant speed

Power of pump Grundfos UPSO 25-65 180 (Extra EU)

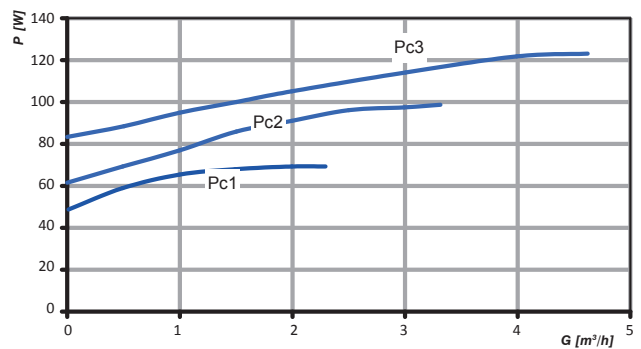

Pvc: Power consumption

## Features

The thermostatic regulating group consists of:

- Front insulation shell (1),
- Rear insulation shell (2),
- Central front insulation shell (3),
- Flow line (4) including thermostatic mixing valve, shut-off valve, temperature gauge and pump,
- Return line (5) including ball shut-off valve, check valve and temperature gauge.

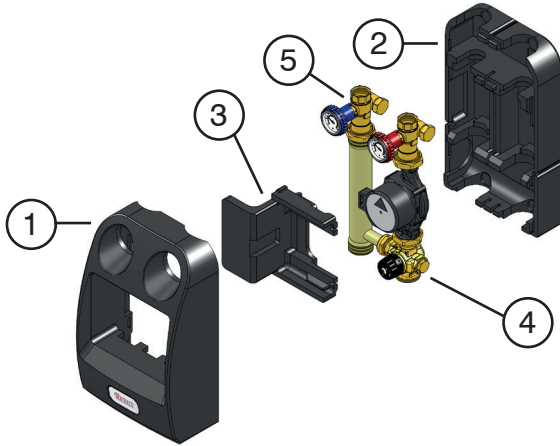

### Advantages

**Energy saving:** the front (1) and rear shells (2) help the thermal insulation of the group and allow energy saving.

**Frontal devices:** all devices, such as the pump menu, temperature gauges, shut-off valves and, in mixed groups, the thermostatic valve and actuator, are frontal. This allows fast regulation and functional check, in particular for the installation of several groups very close to one another.

**Differential by-pass valve:** 02G.DN25 groups are fitted for a differential by-pass valve within the insulation, by installing it between the monoblocs with red and blue knob through the specific connections. In 32G.DN25 and 24G.DN25 series the differential by-pass valve should be installed outside of the group.

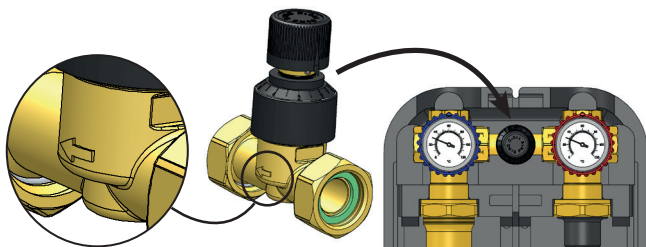

**Heat metering:** 24G.DN25 groups are equipped with specific extension to install energy metering devices, G 3/4 110 mm or G 1 130 mm. They are also complete with pocket for immersion temperature probe on the red knob monobloc.

**Check valve with override:** the groups are factory equipped with a check valve on the return line, placed within the monobloc with blue knob. By rotating at 45° the blue knob, it is possible to override the check valve function, thus allowing the water passage in two directions and making the filling phase of the system much faster. The mixed groups have the T-fitting, connecting the mixing valve, suitable for the insertion of a further removable check valve insert.

**Versatility of the wall mounting bracket:** the universal bracket 42D.DN25 (accessory) makes it possible to install the group with flow upward, downward or with the group laying on a side. Pay however the maximum attention to correctly fix the group to the wall when installed laying on a side.

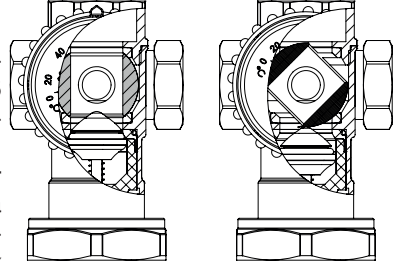

**Transformability:** in case of need, the groups are easily transformable from one version to another (eg. from direct distribution group to thermostatic, mixed and vice versa) as they share the vast majority of components.

**Identical actuators for all DN:** the motorized groups DN 20 can be combined with the same actuators of the DN 25 and DN 32 ranges, allowing a reduction of the models to be purchased and consequently of the warehouse.

**Pump range:** the groups are available with different pump models. For the use of other models and/or manufacturers, it is advisable to contact Barberi for verification.

**Flat gaskets:** the various components of the groups are connected to each other by means of flat seal fittings. This makes the installation faster by avoiding the use of hemp or other sealants.

**Cable glands:** the insulation of the groups is equipped with cable glands pointing upward and downward to allow the cables to be laid safely and tidy.

**Accessibility and maneuverability of the nuts:** by lifting the rear insulation, still applied to the group, it's possible to create the space necessary to maneuver all the nuts, with a suitable hexagonal key, without having to remove it. This is an advantage especially in the wall installation where the insulation is laying against the wall or when pipes pass behind the insulation.

**The nuts are supplied loosened to facilitate the group reversion on the installation field. Fully screw the nuts before installing the group.**

## Installation

The mounting options of the group are:

- Wall installation
- Manifold installation

The group can be installed on manifolds with integrated hydraulic separator, on standard manifolds with independent hydraulic separator, on manifolds connected to a storage.

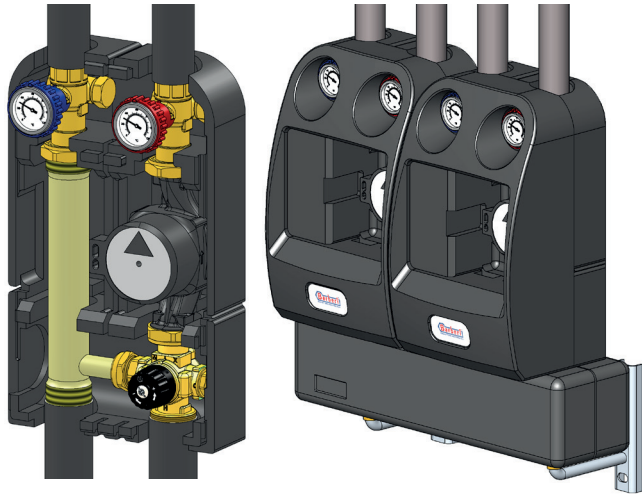

### Group position

The group can be installed in one of the ways shown in the picture, with the pump rotation axis always horizontal. For the UPML AUTO 25-105 180 pump, 3 and 9 o'clock positions are not allowed because:

- 1) the two holes for condensation drain must point upward and downward;
- 2) to solve this problem, it is not allowed anyway to rotate the pump by 90° because the electronic part of the pump would interfere with the pipes, due to its dimensions.

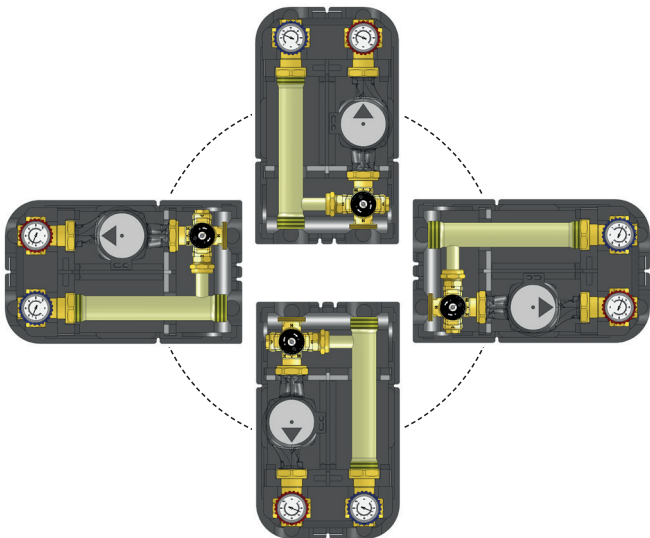

### Group reversibility

The group is factory set with pump on the RH side and flow upwards (or, by rotating it, pump on the LH side and flow downwards). The reversibility is allowed on the installation field by the following procedure:

- 1) Fully unscrew the L extension (or T-joint in 24G.DN25 groups) from the mixing valve.
- 2) Exchange the flow line (1) with the return one (2), by rotating the L extension/T-joint, 180° around its vertical axis.
- 3) Exchange between them the position of the plug and fitting located on the two return ports of the mixing valve.

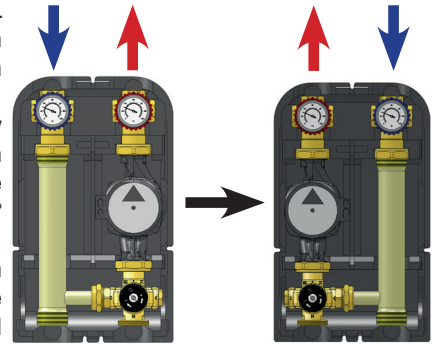

- 4) Connect all the components again and fully screw the nuts.
- Warning: due to the presence of a check valve, keep the ball shut-off valve with red knob on the pump line and the blue knob on the return. For some pump models, it is necessary to rotate the electronic part to place it within the insulation.

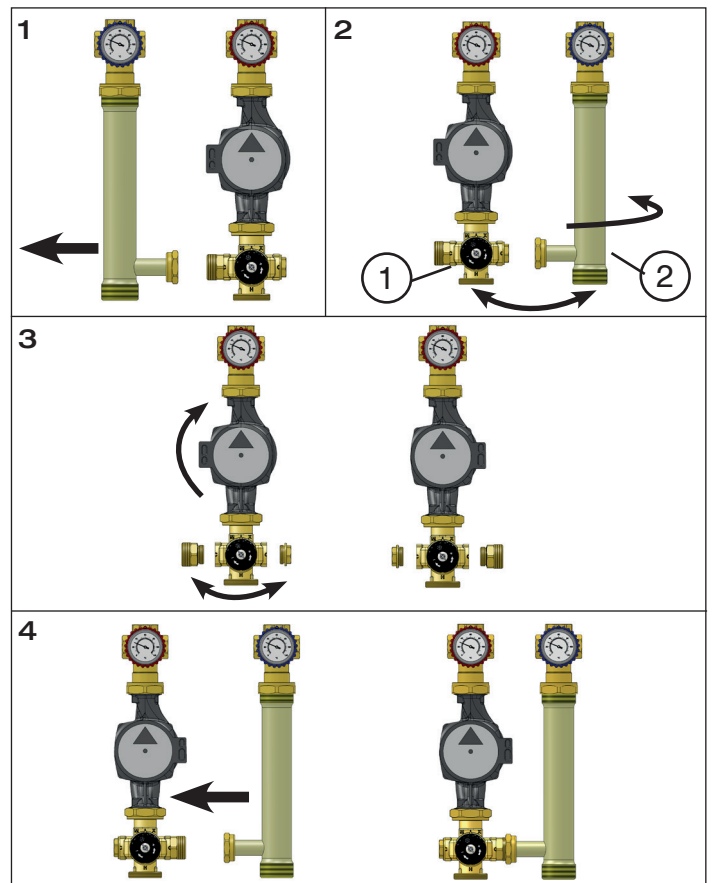

### Adjustment of thermostatic mixing valve

The thermostatic mixing valve keeps constant the temperature of the water supplied to the system. The fixed point regulation is achieved through a thermostatic sensor which moves thanks to the expansion of the wax inside of it. The sensor integrated within the valve is more precise and reliable than the thermostatic valves with external capillary.

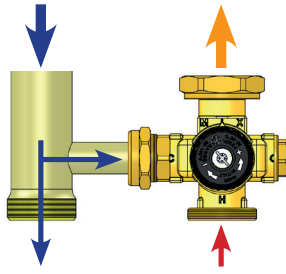

The knob is equipped with a anti-tamper mechanism which makes the rotation difficult, thus avoiding undesired set changes. The mechanism can be released with a screwdriver, slightly loosening the locking screw.

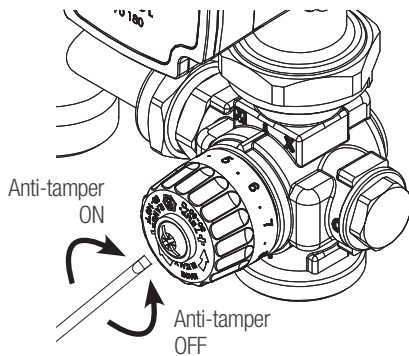

**FIRST SYSTEM START UP.** The fixed point temperature value can be set with the knob before installing the group or, after the installation, exclusively with the **SYSTEM COLD**. To set a temperature value different from the factory one, proceed as follows:

- 1) The graduated scale on the knob corresponds to the temperature values shown in the table below.
- 2) With a screwdriver, slightly loosen the locking screw, holding the knob with your hand.
- 3) Set a mixed water temperature value slightly lower than the design temperature. Activate the generator and wait until it reaches its design working temperature (higher than the valve setting). Activate the pump group. Wait until the mixed water temperature gets stable. Read its value on the flow temperature gauge.
- 4) Counterclockwise rotate step by step the knob to increase the temperature. Then wait until the temperature gets stable. Read its value on the flow temperature gauge. Proceed in the same way until the design temperature is reached.
- 5) When the desired temperature is reached, close the locking screw, holding the knob with your hand.

**NEXT SETTING.** If later a change should be needed in the valve setting, proceed as follows.

Case 1: temperature lower than the current setting. Let the system get cold to obtain at least a return temperature lower than the new valve setting. Follow points 1, 2, 3, 4 and 5.

Case 2: temperature higher than the current setting. In this case, the setting can be carried out also with the system running as well as with the system cold. Follow points 1, 2, 4 and 5.

	25-50 °C	30-60 °C
Min	20 °C	30 °C
1	25 °C	34 °C
2	30 °C	38 °C
3	35 °C	41 °C
4	38 °C	43 °C
5	41 °C	45 °C
6	43 °C	47 °C
7	45 °C	50 °C
8	47 °C	54 °C
Max	50 °C	60 °C
Factory setting	38 °C	45 °C

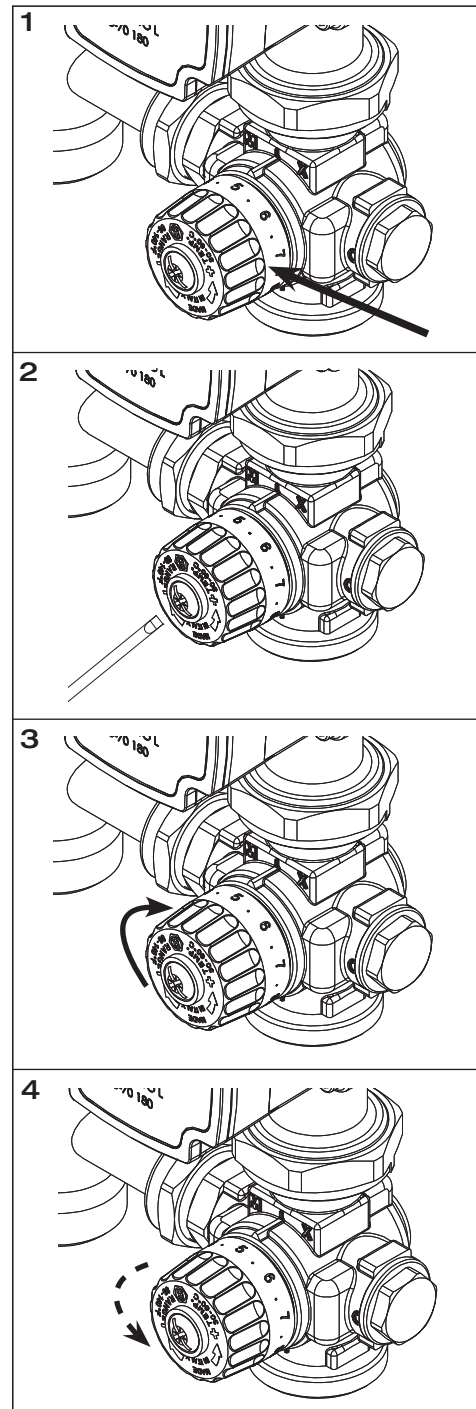

**Differential by-pass valve.**

In variable flow rate systems, managed by regulating valves (for example: thermostatic valves, thermo-electric actuators, zone valves), the modulation and closing of terminals lead to a decrease of the requested flow rate and, as a consequence, an increase of the head on the still open terminals.

The differential by-pass valve:

- limits, at the setting value, the differential pressure between the two installation points, allowing the pump to work closer to the design head conditions and higher efficiency zones;
- by-passes, towards the return, an excess flow rate amount which is proportional to the number of circuits in modulation or closing phase;
- avoids wear and noise (usually hisses and whistles) of the devices in modulation, caused by the speed increase of the fluid when passing through the regulating devices.

The valve setting corresponds to the head losses of the most disadvantaged circuit downstream of the valve or, when installed close to the pump, to the pump design head.

01G.DN25 groups are fitted for the installation of one differential by-pass valve, using the specific connections, between the monoblocs with red and blue knob. The available models are:

- 615015000, setting range 0,2–2,5 m w.g.
- 616015000, setting range 2–6,5 m w.g.

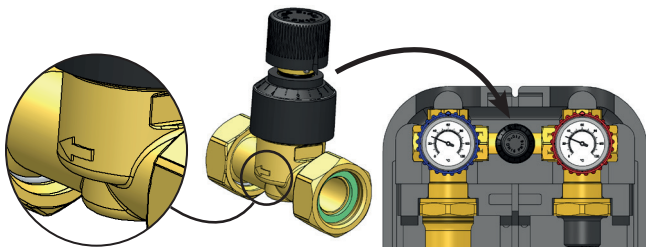
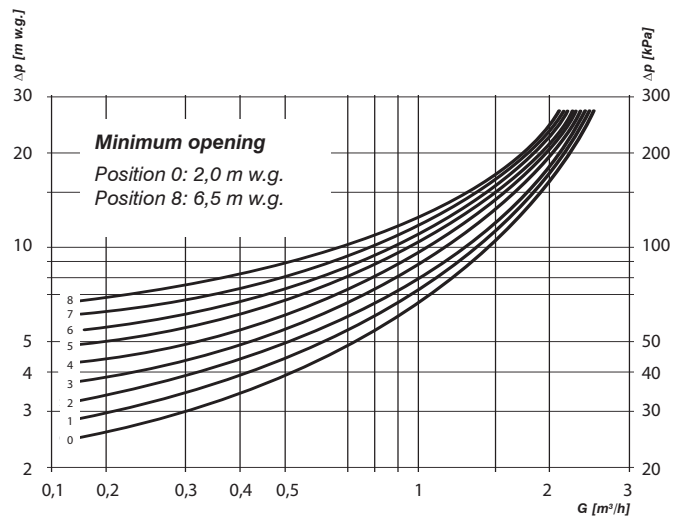
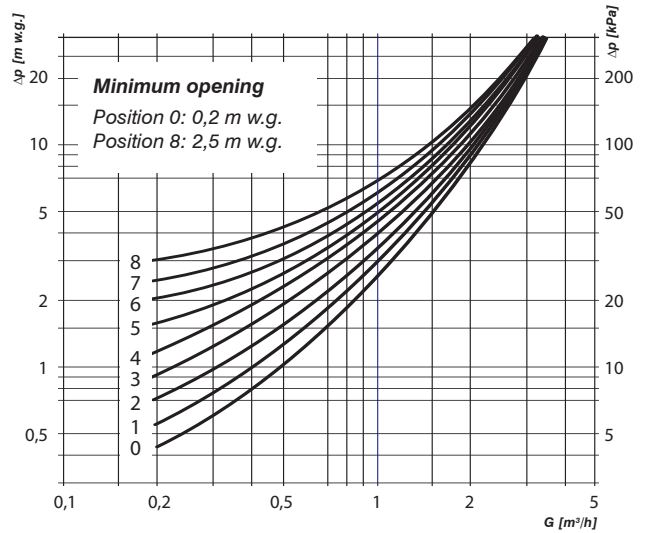

**Cost allocation (heat metering).**

The 24G.DN25 group is fitted for the installation of one energy metering device, using the specific extension on the return side. It's possible to install the following metering devices:

- threaded connections G 3/4, length 110 mm
- threaded connections G 1, length 130 mm.

The extension is composed of a spacer and two pairs of fittings to place the two metering device sizes within the group.

The monobloc with red knob (38D.2 series) of the 24G.DN25 groups is equipped with pocket for immersion probe. By removing the M10 threaded plug, it's possible to insert a probe to collect flow temperature data. The same monobloc has a connection (holder) for anti-tamper sealing.

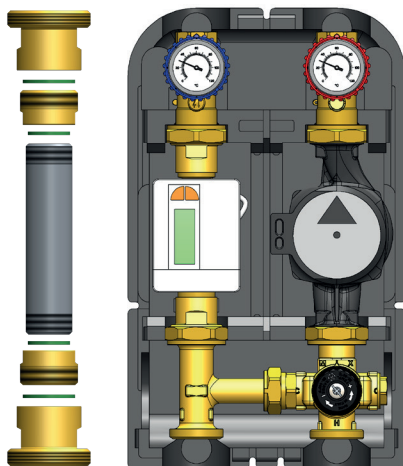



Accessories

## 615

Differential by-pass valve with running nuts - setting range 0,2–2,5 m w.g.. Complete with flat gaskets.

Max working temperature: **110 °C**

Max working pressure: **10 bar**

Connection distance: **65 mm**



Code	Size		
615 015 000	G 3/4 RN	1	40

## 42D.DN25

Bracket for wall mounting of the distribution and regulating groups, with screws and anchors

Hole centre distance: **90 mm**

Hole diameter: **8 mm**



Code		
42D 025 Z00 I	1	25

## 616

Differential by-pass valve with running nuts - setting range 2–6,5 m w.g.. Complete with flat gaskets.

Max working temperature: **110 °C**

Max working pressure: **10 bar**

Connection distance: **65 mm**



Code	Size		
616 015 000	G 3/4 RN	1	40

System diagrams

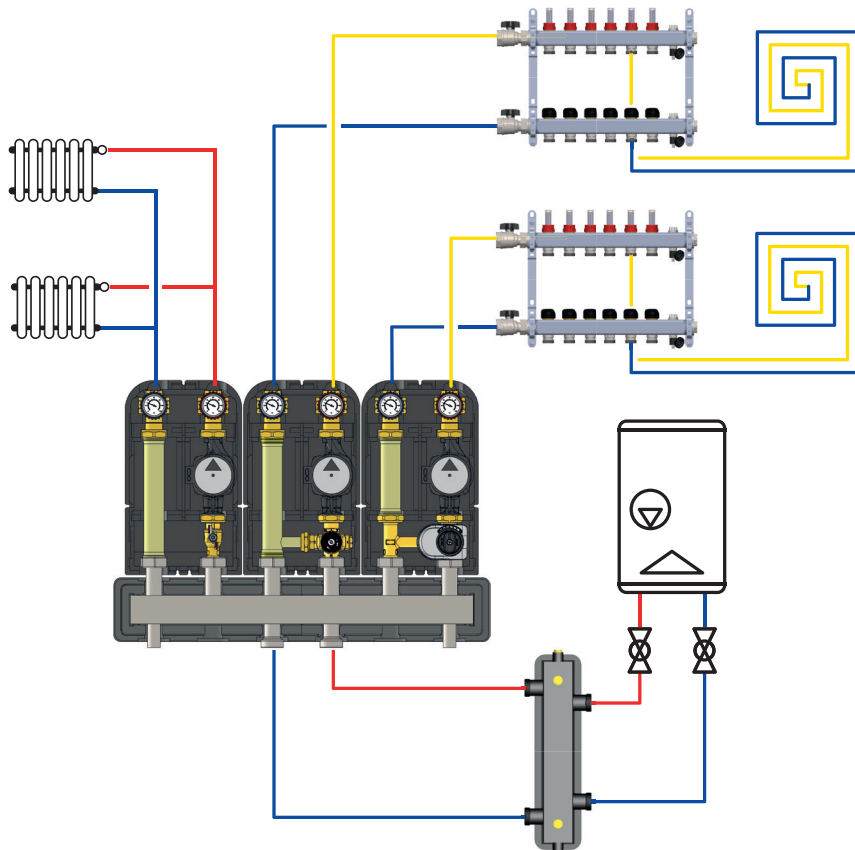

## Specifications

### Series 02G.DN25

Regulating group with thermostatic mixing valve. G 1 1/2 M connections with flat gaskets to the primary circuit and G 1 F connections to the secondary circuit. Centre distance between flow and return connections 125 mm. Height of flow and return lines 363 mm. Dimensions of the group with shell 247x410x212 mm (Width x Height x Depth). The group is composed of: thermostatic mixing valve in brass with wax thermostatic sensor, adjustment range 25–50 °C (and 30–60 °C); ball shut-off valves in brass on the flow and return of the secondary circuit; POM check valve on the return line; flow and return temperature gauges with 0–120 °C scale. High-efficiency pump Wilo Para 25-180/7-50/SC-12 (Grundfos UPM3 AUTO 25-70 180, Grundfos UPML AUTO 25-105 180, 3 constant speed pump Grundfos UPSO 25-65 180 (Extra EU)), electric supply 230 V (50 Hz). Insulation shell in EPP. Working temperature range 5–90 °C. Maximum working pressure 10 bar. Reversible group. Equipped with connections for optional differential by-pass valve.

### Series 32G.DN25

Regulating group with thermostatic mixing valve. G 1 1/2 M connections with flat gaskets to the primary circuit and G 1 F connections to the secondary circuit. Centre distance between flow and return connections 125 mm. Height of flow and return lines 363 mm. Dimensions of the group with shell 247x410x212 mm (Width x Height x Depth). The group is composed of: thermostatic mixing valve in brass with wax thermostatic sensor, adjustment range 25–50 °C (and 30–60 °C); ball shut-off valves in brass on the flow and return of the secondary circuit; POM check valve on the return line; flow and return temperature gauges with 0–120 °C scale. High-efficiency pump Wilo Para 25-180/7-50/SC-12 (Grundfos UPM3 AUTO 25-70 180, Grundfos UPML AUTO 25-105 180, 3 constant speed pump Grundfos UPSO 25-65 180 (Extra EU)), electric supply 230 V (50 Hz). Insulation shell in EPP. Working temperature range 5–90 °C. Maximum working pressure 10 bar. Reversible group. Without connections for optional differential by-pass valve.

### Series 24G.DN25

Regulating group with thermostatic mixing valve. G 1 1/2 M connections with flat gaskets to the primary circuit and G 1 F connections to the secondary circuit. Centre distance between flow and return connections 125 mm. Height of flow and return lines 363 mm. Dimensions of the group with shell 247x410x212 mm (Width x Height x Depth). The group is composed of: thermostatic mixing valve in brass with wax thermostatic sensor, adjustment range 25–50 °C (and 30–60 °C); ball shut-off valves in brass on the flow and return of the secondary circuit; POM check valve on the return line; flow and return temperature gauges with 0–120 °C scale. High-efficiency pump Wilo Para 25-180/7-50/SC-12 (Grundfos UPM3 AUTO 25-70 180, Grundfos UPML AUTO 25-105 180, 3 constant speed pump Grundfos UPSO 25-65 180 (Extra EU)), electric supply 230 V (50 Hz). Insulation shell in EPP. Working temperature range 5–90 °C. Maximum working pressure 10 bar. Reversible group. Without connections for optional differential by-pass valve. Fitted for G 3/4 110 mm or G 1 130 mm energy metering device installation on the return line. Complete with M10 pocket for immersion probe on the flow line and connection for anti-tamper sealing.