

RECESSED REGULATING GROUP WITH THERMOSTATIC MIXING VALVE

Description



Pre-assembled pump group for fixed point regulation and circulation of mixed fluid. Allows the circulation of the thermal fluid, coming from the primary circuit, by keeping the temperature at a pre-set value (fixed point) through the help of a mixing valve with thermostatic element. It is used in heating systems in general and radiant panel systems. The group is composed of a pump, thermostatic mixing valve, flow temperature gauge, manual air vent, fittings for secondary distribution manifolds. The group can be installed with the secondary distribution manifolds on the right or the left. Available with two temperature adjustment ranges (30–60 °C for 17B.N and 18B.N series, 25–50 °C for 17B.1.N and 18B.1.N series). The groups 18B.N and 18B.1.N are equipped with 07B.N series differential by-pass kit as standard.

Range of products

Recessed regulating group with thermostatic mixing valve	XXX	XXX	X	X	X
Without differential by-pass kit	17B				
With differential by-pass kit 2–6,5 m w.g. (07B.N series)	18B				
Pump threaded connections G 1 1/2		040			
Nickel-plated finish			N		
Adjustment range 30–60 °C (XXX.N series)				0	
Adjustment range 25–50 °C (XXX.1.N series)				1	
Pump Grundfos UPM3 AUTO 25-70 130					T
Pump Wilo Para 25-130/7-50/SC-12					P
Pump Grundfos UPSO 25-65 130 (Extra EU)					O
Without pump					X

Features

Working temperature range: **5–90 °C**
 Max working pressure: **10 bar**
 Male threaded connections: **ISO 228-1**
 Connection centre distance to secondary manifold: **211 mm**
 Pump: **Grundfos UPM3 AUTO 25-70 130**
Wilo Para 25-130/7-50/SC-12
Grundfos UPSO 25-65 130 (Extra EU)
 Suitable fluids: **water, glycol solutions (max 30%)**
 Temperature adjustment range: **30–60 °C and 25–50 °C**
 Accuracy: **±2 °C**
 Factory setting: **45 °C (30–60 °C) e 38 °C (25–50 °C)**
 Temperature gauge scale: **0–80 °C**

Materials

Instrument holder fitting: **brass EN 12165 CW617N**
 Fittings for secondary manifold:
 • Body: **brass EN 12164 CW617N**
 • Gasket: **EPDM**
 Elbow fitting: **brass EN 12165 CW617N**

Thermostatic mixing valve

- Body: **brass EN 1982 CB753S**
- Gaskets: **EPDM**
- Headwork: **brass EN 12164 CW617N**
- Spring: **stainless steel AISI 302**
- Thermostatic sensor: **wax**
- Knob: **ABS**

Pump

- Body: **cast iron**
- Electric supply: **230 V-50/60 Hz**
- Protection class:
 Grundfos UPM3: **IP 44**
 Wilo Para: **IPx4D**
 Grundfos UPSO (Extra EU): **IP 44**
- Centre distance: **130 mm**
- Connections: **G 1 1/2 M (ISO 228-1)**
- Gaskets: **EPDM**

Features 07B.N

Working temperature range: **0 (no frost)–90 °C**
 Max working pressure: **10 bar**
 Setting: **2–6,5 m w.g.**
 Connection distance: **55 mm**
 Suitable fluids: **water for thermal systems, glycol solutions (max 50%)**
 Threaded connections: **ISO 228-1**

Materials 07B.N

Body, headwork and nuts: **brass EN 12165 CW617N**
 Obturator and locking nut: **brass EN 12164 CW614N**
 Spring: **stainless steel**
 Knob and graduated scale: **ABS**
 Obturator gasket: **NBR**
 Gaskets: **NBR**
 Nut gaskets: **non asbestos fiber**
 Elbow pipe: **copper**
 Running nuts: **brass EN 12164 CW617N**

Components

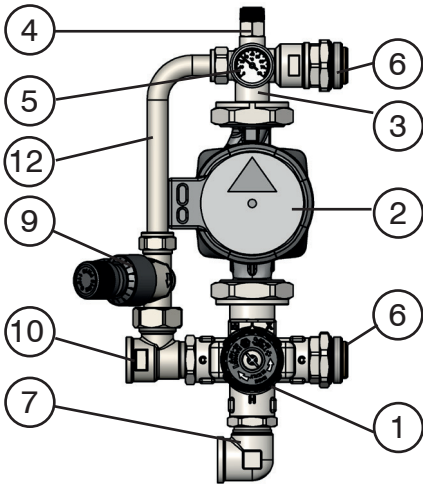

18B.N
18B.1.N

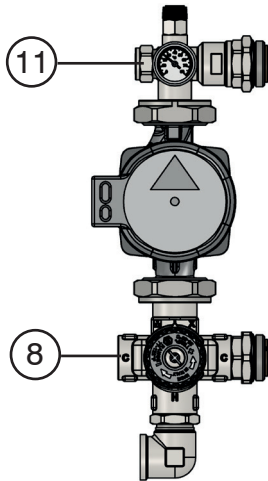

17B.N
17B.1.N

17B.N-17B.1.N-18B.N-18B.1.N		
2	Pump	Grundfos UPM3 AUTO, Wilo Para, Grundfos UPSO (Extra EU)
1	Thermostatic mixing valve	
3	Instrument holder fitting	
4	Manual air vent	
5	Temperature gauge	
6	Running fittings for secondary manifold	
7	Elbow fitting for primary side flow	
8	Connection for primary side return	
9	Differential by-pass kit	
10	Adjustable Tee fitting for differential by-pass kit connection	
11	Plug	
12	By-pass pipe	

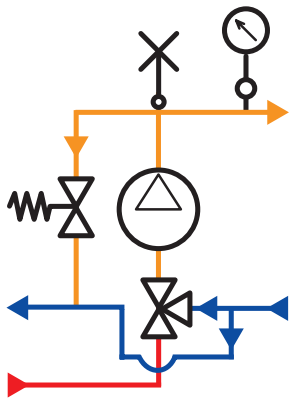

- Pump
- Thermostatic mixing valve
- Manual air vent
- Temperature gauge
- Differential by-pass valve

Dimensions

Code	P [bar]	L1 [mm]	L2 [mm]	L3 [mm]	Pump	Weight [kg]	N. P/B	N. P/C
17B 040NOT-17B 040N1T	10	91	36	140	Grundfos UPM3 AUTO 25-70 130	3,6	-	1
17B 040NOP-17B 040N1P	10	93	33	115	Wilo Para 25-130/7-50/SC-12	3,42	-	1
17B 040N00-17B 040N10	10	101	25	144	Grundfos UPSO 25-65 130 (Extra EU)	4,15	-	1
17B 040NOX-17B 040N1X	10	-	-	-	Without pump	1,67	1	5
18B 040NOT-18B 040N1T	10	91	36	-	Grundfos UPM3 AUTO 25-70 130	4,17	-	1
18B 040NOP-18B 040N1P	10	93	33	-	Wilo Para 25-130/7-50/SC-12	3,99	-	1
18B 040N00-18B 040N10	10	101	25	-	Grundfos UPSO 25-65 130 (Extra EU)	4,72	-	1
18B 040NOX-18B 040N1X	10	-	-	-	Without pump	1,67	1	5
07B 015N00	10	-	-	-	-	0,57	-	-

N. P/B: number of pieces in box - N. P/C: number of pieces in carton
 Other pump types should be evaluated

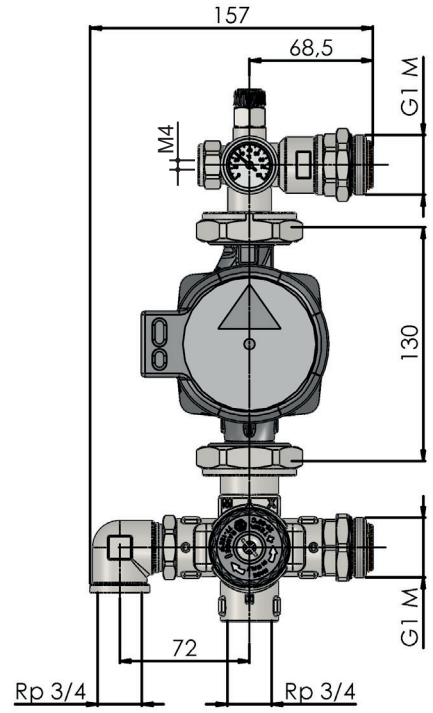
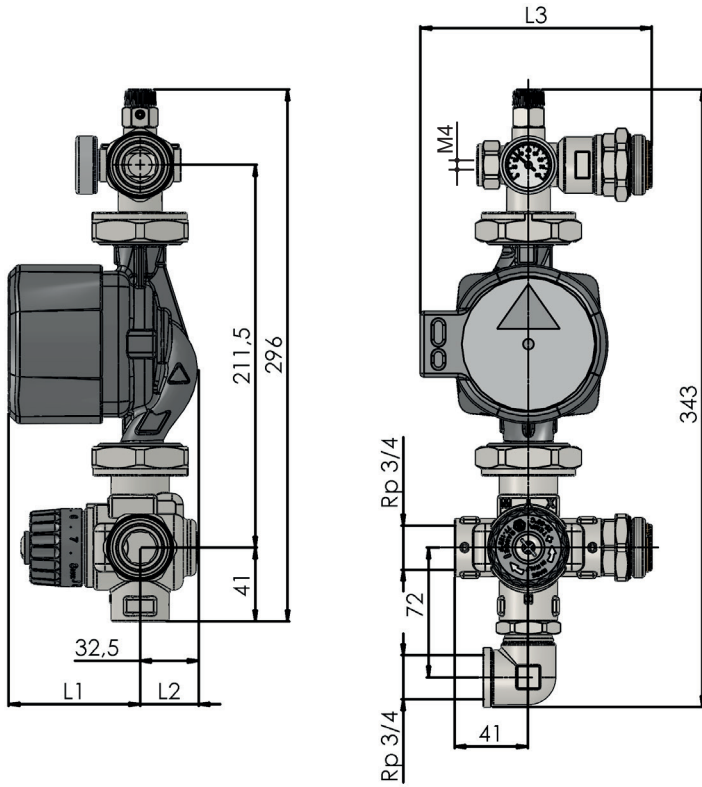

17B.N
17B.1.N

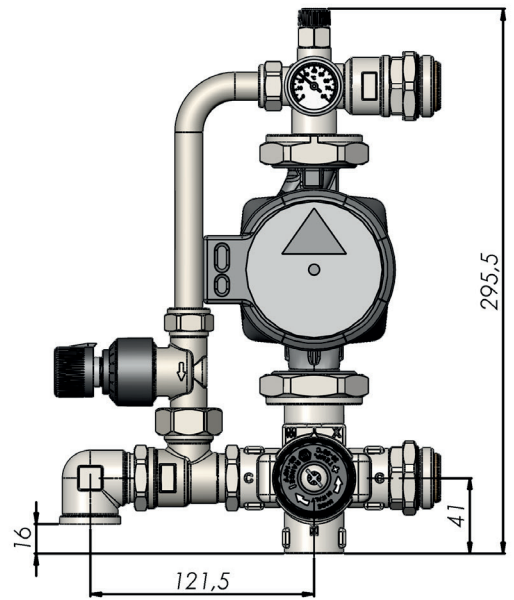
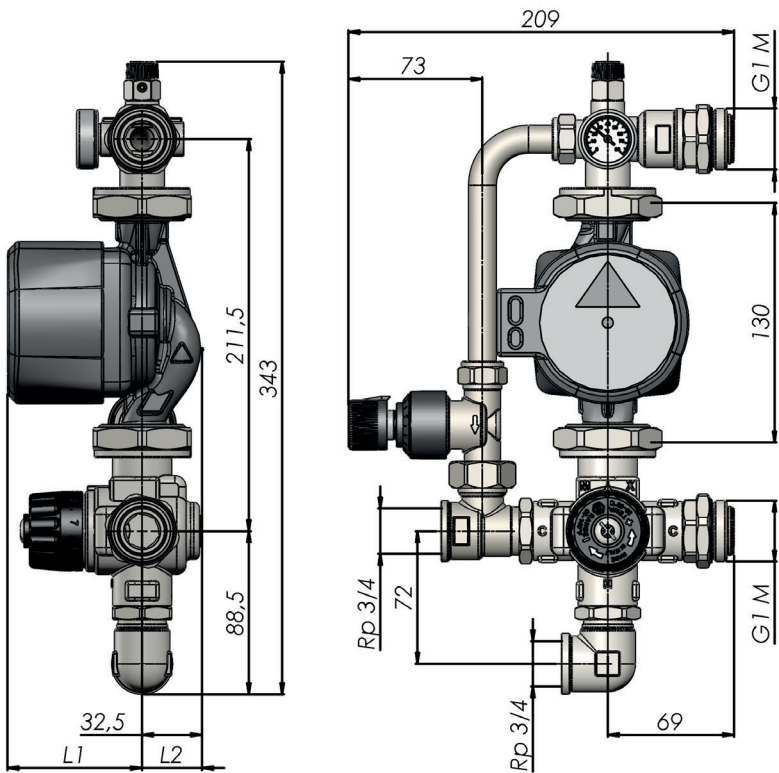

18B.N
18B.1.N

Diagrams

Group sizing (operation for specialized/authorized technical personnel).

Step 1: head losses of the group without pump. Enter on the x-axis of the first diagram with the design flow rate value. Cross the curve of the group and read the corresponding head losses of the group (without pump) on the y-axis.

Step 2: available head of the pump. With the same design flow rate value, enter on the x-axis of the selected pump diagram ("Head of pump"). Cross the curve of the selected working mode (Constant speed, Proportional pressure, Constant pressure) and read the corresponding available head of the pump on the y-axis.

Step 3: pump validation. Calculate the difference between the available head of the pump and the head losses of the group without pump. The remaining pump head should be higher than the head losses of the rest of the system: if so, the selected pump is suitable to supply water to the rest of the system, otherwise a different pump working mode or pump size or different group size or a system resizing could be necessary.

Hydraulic characteristics: head losses of the thermostatic regulating group without pump

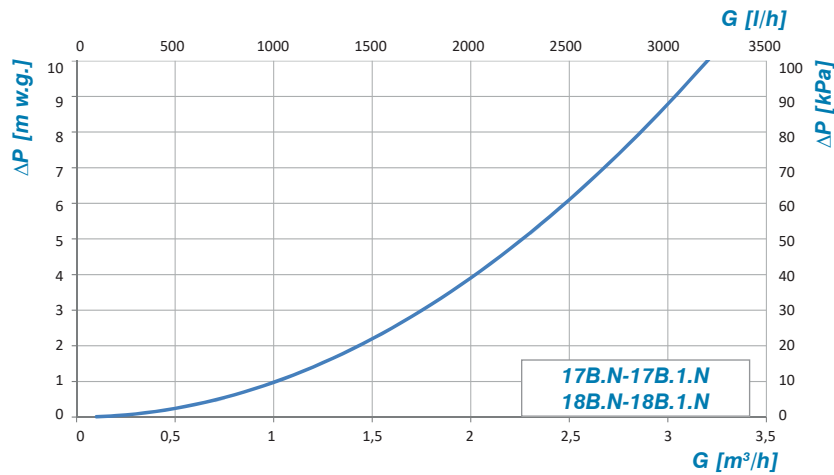

Head and power consumption of the pumps

Head of pump Wilo Para 25-130/7-50/SC-12

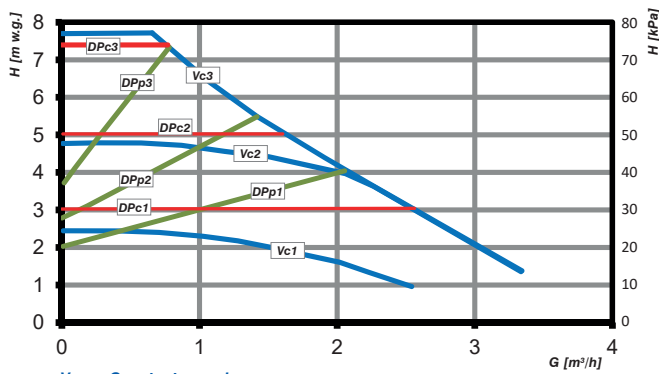

Vc: Constant speed
DPP: Proportional pressure
DPC: Constant pressure

Power of pump Wilo Para 25-130/7-50/SC-12

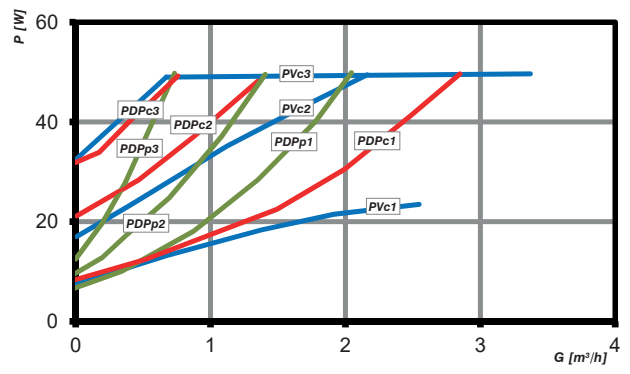

PVC: Power consumption at constant speed
PDPp: Power consumption at proportional pressure
PDPc: Power consumption at constant pressure

Head of pump Grundfos UPM3 AUTO L 25-70 130

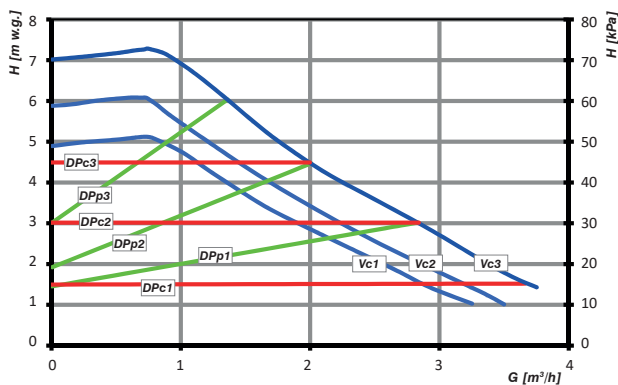

Vc: Constant speed
DPP: Proportional pressure
DPC: Constant pressure

Power of pump Grundfos UPM3 AUTO L 25-70 130

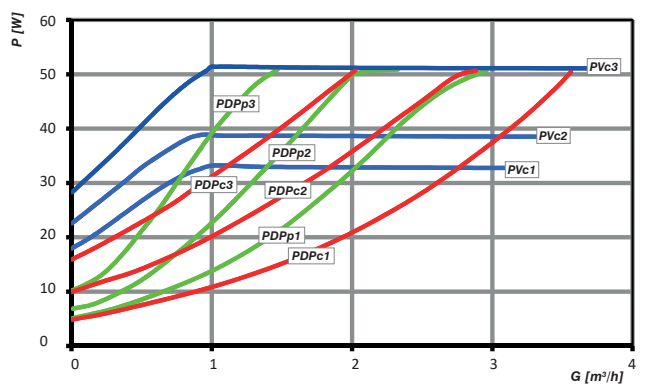

PVC: Power consumption at constant speed
PDPp: Power consumption at proportional pressure
PDPc: Power consumption at constant pressure



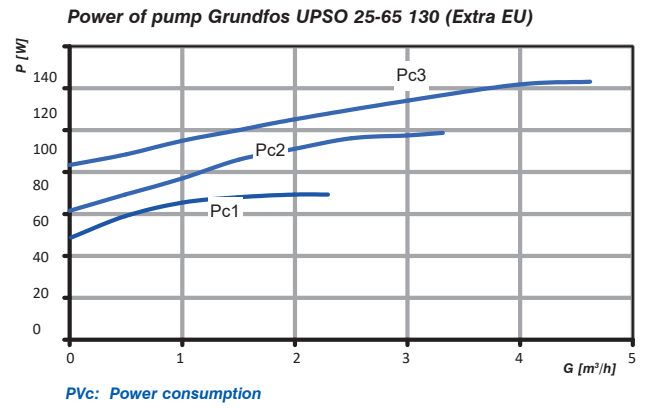
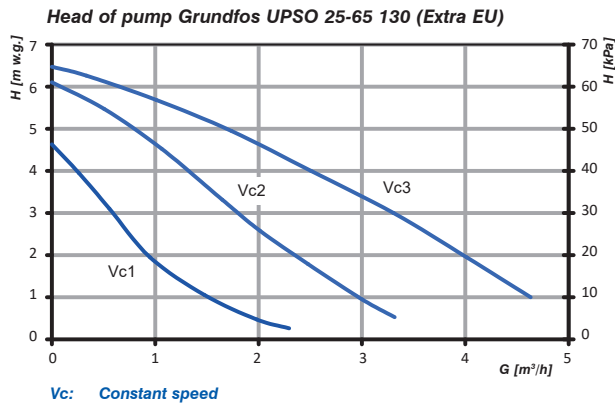

Features

The thermostatic regulating group consists of:

- Thermostatic mixing valve (1);
- Flow line including elbow fitting for primary flow (7), pump (2), instrument holder fitting (3), manual air vent (4), temperature gauge (5), adjustable fitting for secondary manifold (6);
- Return line including adjustable fitting for secondary manifold (6), tee built-into the valve (1).
- 07B.N series differential by-pass kit: connects the system flow to the primary return (supplied as standard in 18B.N and 18B.1.N groups, optional for other groups).

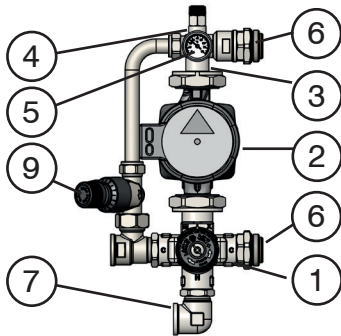

Advantages

Compact installation: the 211 mm centre distance to the secondary manifold and the 130 mm pump make the installation very compact.

Temperature gauge: the group is both frontally and rear equipped with a pocket to place the provided temperature gauge to check the temperature of the mixed water supplied to the system (fig. A).

Pump range: the groups are available with three different pump models. For the use of other models and/or manufacturers, it is advisable to contact Barberi for verification.

Gaskets: the various components of the groups are connected to each other by means of provided gaskets. This makes the installation faster by avoiding the use of hemp or other sealants.

Fittings to secondary manifold: the groups are already complete with fittings to be screwed to the main connections of the secondary manifold (fig. B).

Elbow fitting (7): this fitting allows to connect the primary side pipes arriving from the left or the bottom (fig. C).

Reversibility: the group can be easily inverted from right to left by following a specific procedure (fig. D).

Flexibility of installation. The group can be installed on wall, in box or recessed (fig. E).

Anti-tamper device. The device, placed within the mixing valve knob, avoids undesired variations of the setting. Slightly unscrewing the knob screw, the device is deactivated to allow the valve setting. By tightening the knob screw again, the anti-tamper is restored (fig. F).

M4 threaded connection (only for 17B.N-17B.1.N): fitted for the connection of an optional safety thermostat (fig. G).

The nuts are supplied loosened to facilitate the pump rotation on the installation field. Fully screw the nuts before installing the group.

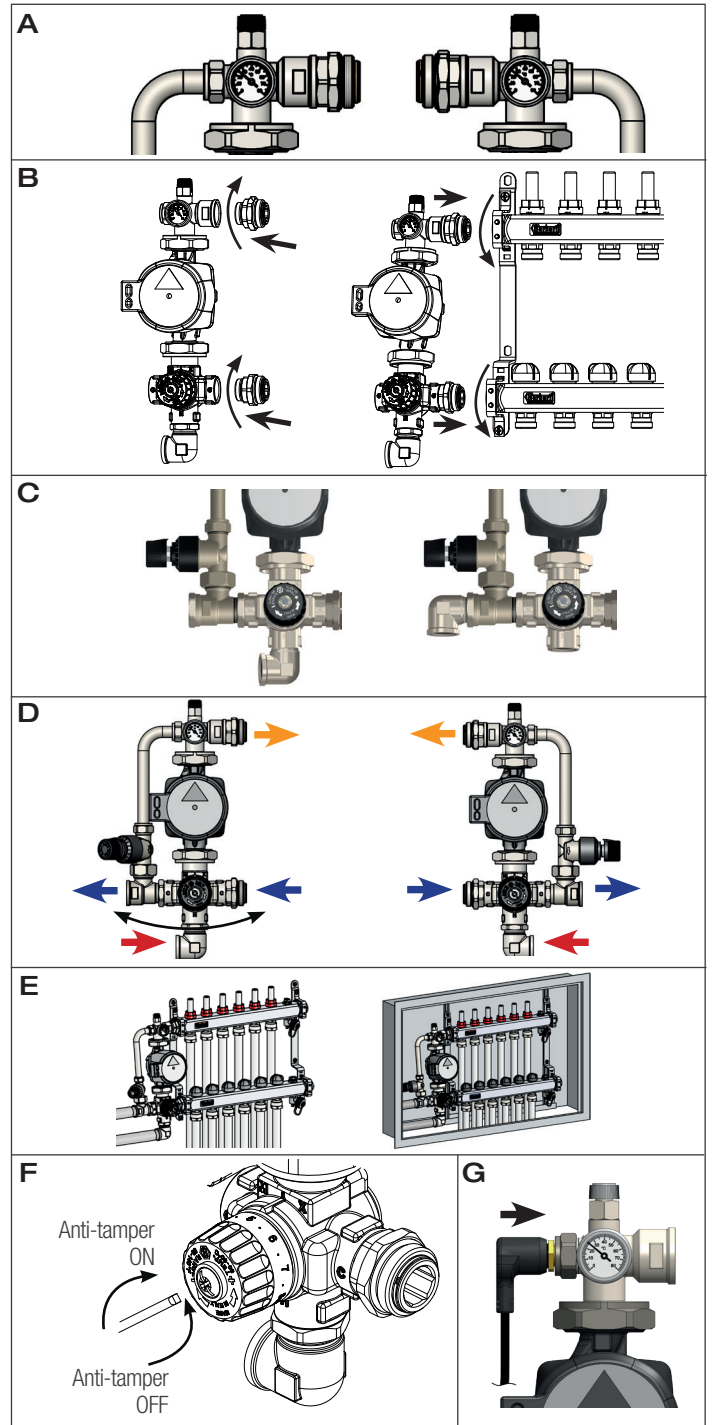

Installation

The mounting options of the group are:

- Wall installation
- Recessed installation
- Box installation

The group can be directly connected to a generator if the latter is not equipped with a pump. Instead, if the generator is equipped with a pump, an hydraulic separator should be placed between the generator and the group, in order to avoid mutual influences between the pumps. The group can be installed downstream of an inertial water storage, which performs the function of an hydraulic separator.

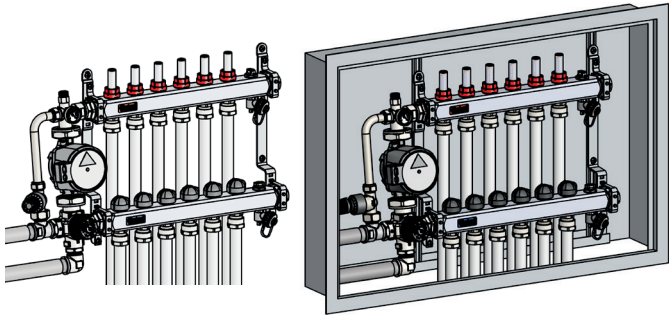

Group position

The group can be installed in one of the ways shown in the picture, with the pump rotation axis always horizontal.

12 o'clock position: suggested.

3 o'clock position: allowed only if the secondary manifold (directly connected to the group) is not equipped with flow meters or it is placed in remote position (only system flow and return pipes are directly connected to the group).

6 o'clock position: allowed but the manual air vent cannot be used anymore since it is placed upside down.

9 o'clock position: see 3 o'clock. Furthermore, adjust correctly the differential by-pass valve (it is not allowed to install it pointing downward).

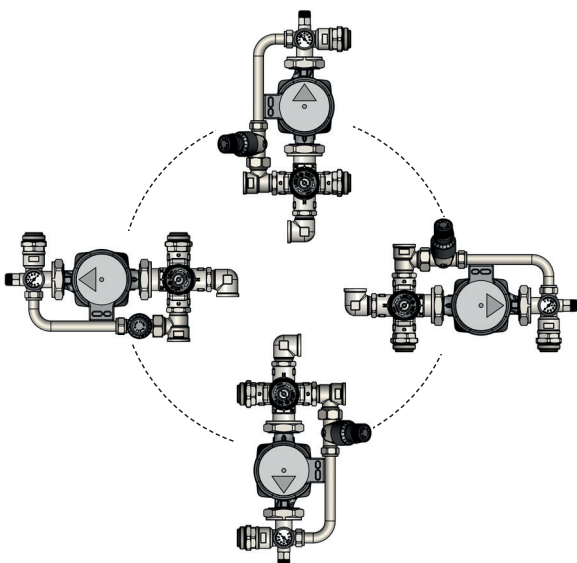

Group reversibility

The group is supplied pre-assembled in left hand version, ready to be connected to the manifolds at its right side. To reverse the group, unscrew the running fitting (6), connected to the system return port of the valve (1), and screw it to the opposite port of the valve, using the same G 3/4 locking ring. Loosen the running nut downstream of the pump and rotate the instrument holder fitting (3) by 180°, aligning it to the mixing valve. Slightly screw the running nut to keep the alignment. Insert the temperature gauge (5) into the specific pocket on the instrument holder fitting (3). The group is now ready to be installed at the right of the manifold. Follow the procedure to connect the manifold. Fully screw the running nut downstream of the pump. If necessary, install the differential by-pass valve (9) by reading the specific procedure.

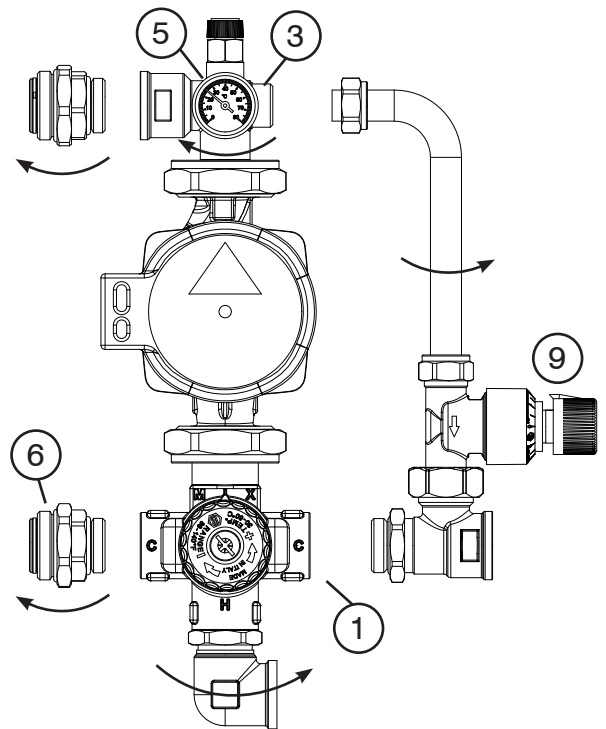

Adjustment of the thermostatic mixing valve

The thermostatic mixing valve keeps constant the temperature of the water supplied to the system. The fixed point regulation is achieved through a thermostatic sensor which moves thanks to the expansion of the wax inside of it. The sensor integrated within the valve is more precise and reliable than the thermostatic valves with external capillary.

The knob is equipped with an anti-tamper mechanism which makes the rotation difficult, thus avoiding undesired set changes. The mechanism can be released with a screwdriver, slightly loosening the locking screw.

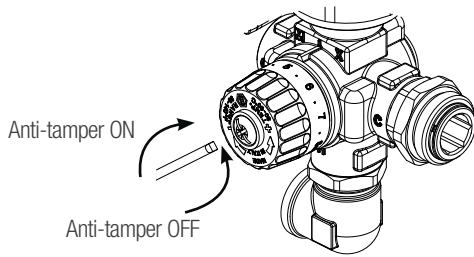

FIRST SYSTEM START UP. The fixed point temperature value can be set with the knob before installing the group or, after the installation, exclusively with the **SYSTEM COLD**. To set a temperature value different from the factory one, proceed as follows:

1) The graduated scale on the knob corresponds to the temperature values shown in the table.

2) With a screwdriver, slightly loosen the locking screw, holding the knob with your hand.

3) Set a mixed water temperature value slightly lower than the design temperature. Activate the generator and wait until it reaches its design working temperature (higher than the valve setting). Activate the group pump. Wait until the mixed water temperature gets stable. Read its value on the flow temperature gauge.

4) Counterclockwise rotate step by step the knob to increase the temperature. Then wait until the temperature gets stable. Read its value on the flow temperature gauge. Proceed in the same way until the design flow temperature is reached.

5) When the desired temperature is reached, close the locking screw, holding the knob with your hand.

	30-60 °C	25-50 °C
	°C	°C
Min	30	20
1	34	25
2	38	30
3	41	35
4	43	38
5	45	41
6	47	43
7	50	45
8	54	47
Max	60	50
	45	38

NEXT SETTING. If later a change should be needed in the valve setting, proceed as follows.

Case 1: temperature lower than the current setting. Let the system get cold to obtain at least a return temperature lower than the new valve setting. Follow points 1, 2, 3, 4 and 5.

Case 2: temperature higher than the current setting. In this case, the setting can be carried out also with the system running as well as with the system cold. Follow points 1, 2, 4 and 5.

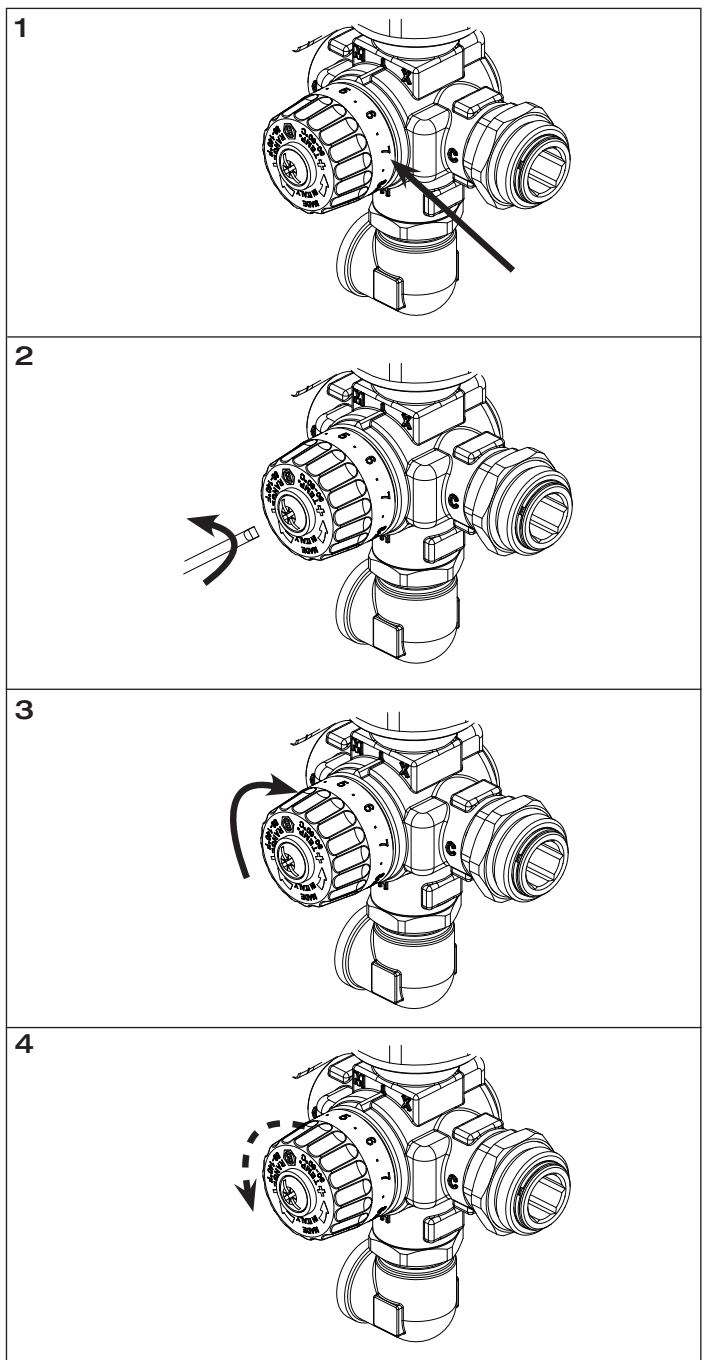
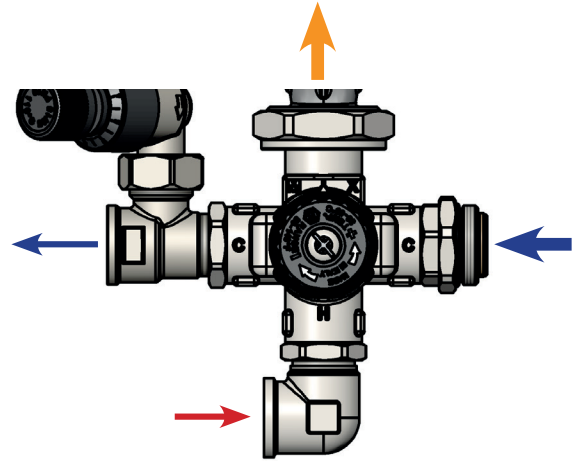

Differential by-pass kit

In variable flow rate systems, managed by regulating valves (for example: thermostatic valves, thermo-electric actuators, zone valves), the modulation and closing of terminals lead to a decrease of the requested flow rate and, as a consequence, an increase of the head on the still open terminals.

The differential by-pass valve:

- limits, at the setting value, the differential pressure between the two installation points, allowing the pump to work closer to the design head conditions and higher efficiency zones;
- by-passes, towards the return, an excess flow rate value which is proportional to the number of circuits in modulation or closing phase;
- avoids wear and noise (usually hisses and whistles) of the devices in modulation, caused by the speed increase of the fluid when passing through the regulating devices.

The differential by-pass valve, provided as standard in 18B.N and 18B.1.N groups, optional in 17B.N and 17B.1.N groups, is installed between the flow and the return of the system through the specific connections on the group.

The valve setting corresponds to the pump design head.

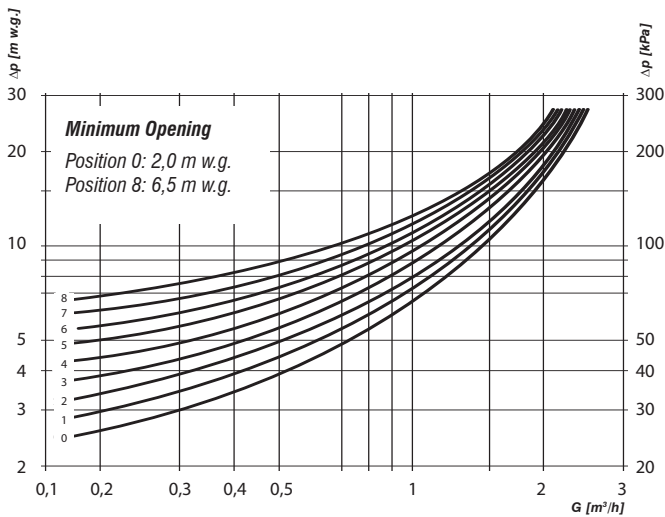

The by-pass kit is composed of an adjustable Tee fitting (10) with O-Ring and locking ring, a differential by-pass valve (9), a by-pass pipe (12) and a set of connection fittings. The kit is supplied unassembled to be applied to the left or right version on the installation field. Installation:

Fig. I1) screw the male thread of the adjustable Tee (10) to the boiler return connection (8) of the mixing valve (1) until the O-Ring comes into contact with its seat on the valve. Further screw it by one more turn to align the flat face of the Tee (10) to the by-pass connection on the upper instrument holder fitting (3).
 Fig. I2) Remove the plug (11) of the instrument holder fitting (3). Place the flat gasket (13) on the adjustable Tee seat (10), place the by-pass valve running nut (9) on the gasket and screw by one turn. Tilt the by-pass kit and insert the long end of the by-pass pipe (12) into the 15 mm compression end of the by-pass valve (9). Assemble the 15 mm nut and olive onto the short end of the pipe (12) and rotate the whole assembly to insert the pipe fully into the connection on the instrument holder fitting (3).

Fig. I3) Adjust correctly the differential by-pass valve (9) (it is not allowed to install it pointing downward). Fully screw all the nuts.

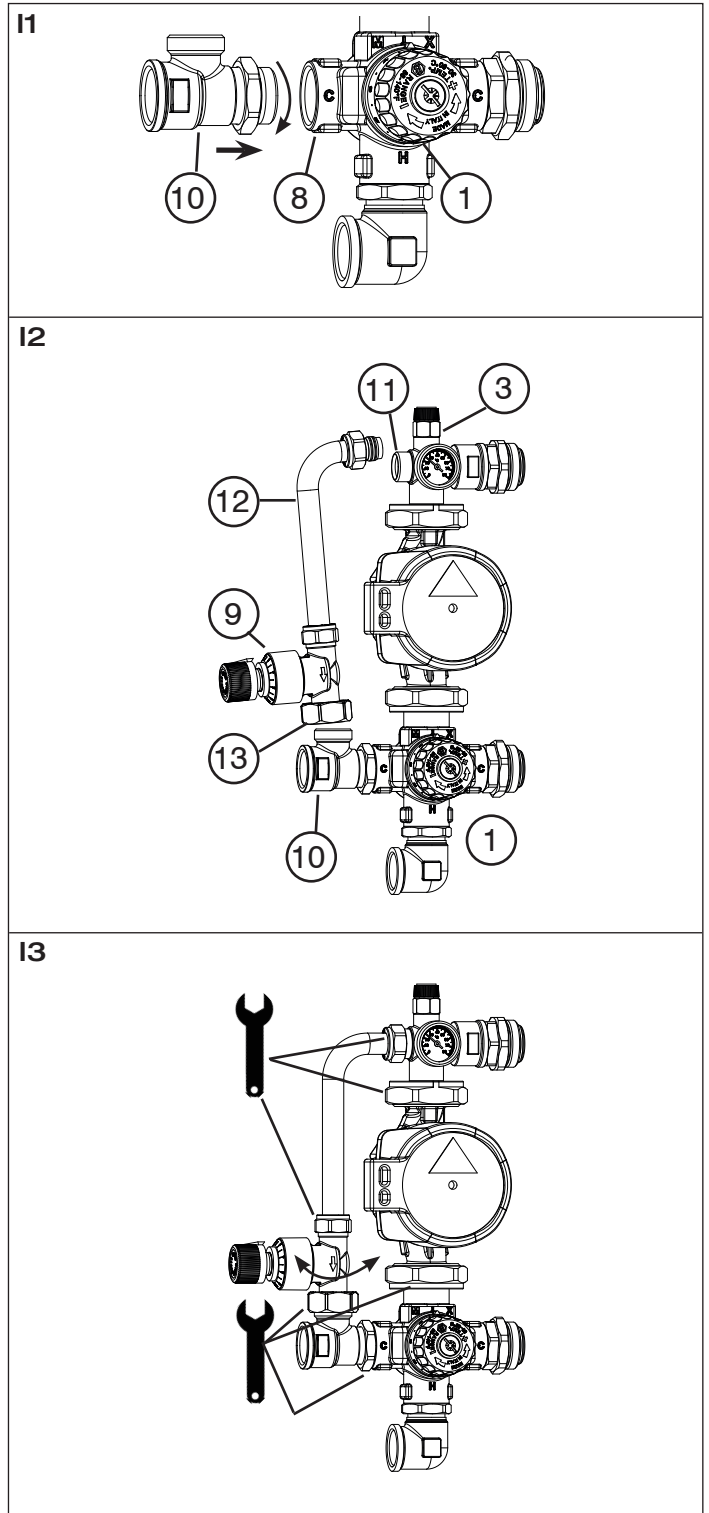

Accessories

99B

Safety thermostat kit for distribution and regulating recessed groups 27B.N-29B.N-30B.N-17B.N-17B.1.N. Normally closed with 55 °C setting, pre-wired box.



Code

1	-

99B 004 005 2

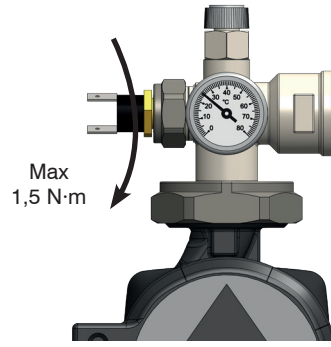

99B
99B.07

99B.07

Safety thermostat kit for distribution and regulating recessed groups 27B.N-29B.N-30B.N-17B.N-17B.1.N. Normally closed with 55 °C setting.



Code

1	-

99B 004 007

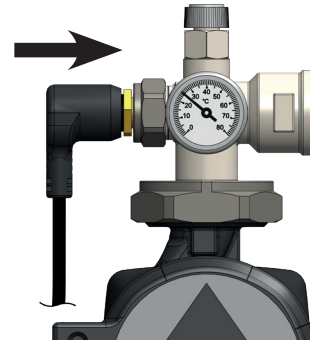

P91.0

Pair of ball shut-off valves. Red and blue handle, with female and union connections.

Working temperature range: **-20–120 °C**
Max working pressure: **30 bar**

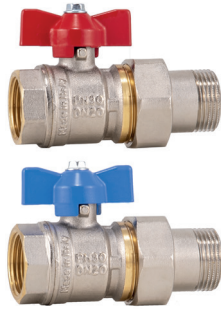

Code

Size

Knob colour



P91 020 N01 011

G 3/4 F - G 3/4 M

red/blu

10 20

07B.N

Differential by-pass kit - setting 2–6,5 m w.g.. Yellow versions on request.

Max working temperature: **95 °C**
Max working pressure: **10 bar**
Connection centre distance to group: **211 mm**



Code

Size



07B 015 N00

15 mm - G 3/4 M - Rp 3/4

15

System diagrams

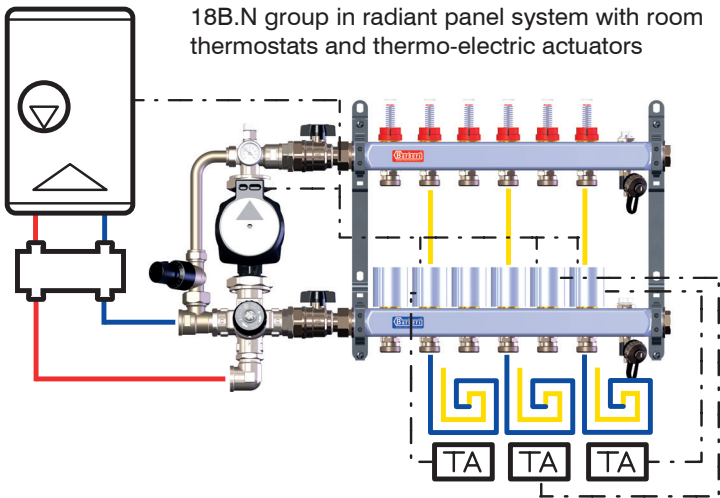

P91.0: use as primary shut-off valves for 17B.N and 18B.N groups

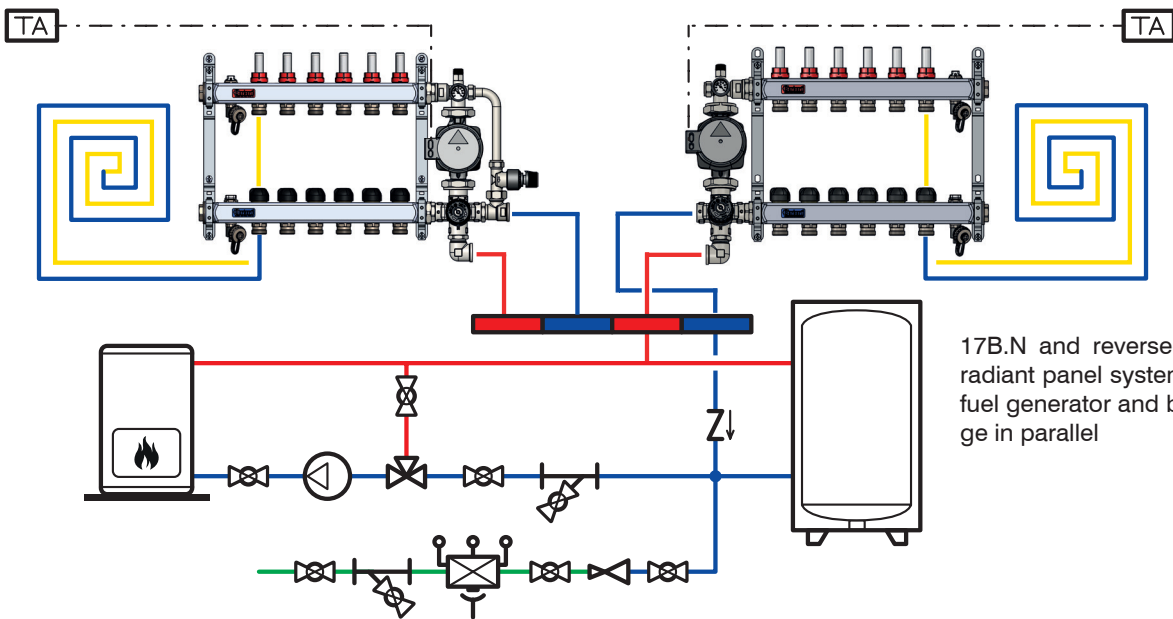
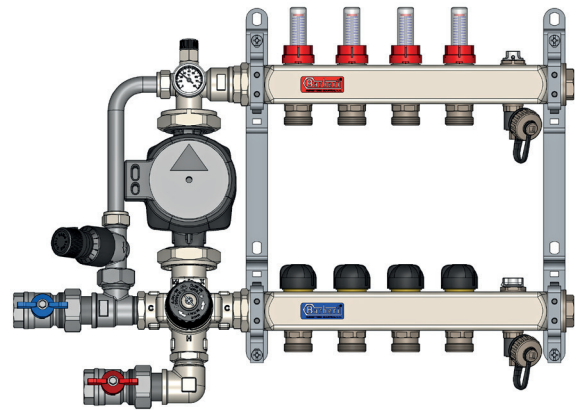

Specifications

Series 17B.N-17B.1.N-18B.N-18B.1.N

Recessed regulating group with thermostatic mixing valve. Threaded connections Rp 3/4 - G 1 M. Connection centre distance to secondary manifold 211 mm. The group is composed of: brass thermostatic mixing valve with wax sensor, temperature adjustment range 30–60 °C (17B.N and 18B.N series) and 25–50 °C (17B.1.N and 18B.1.N series); brass instrument holder; flow temperature gauge with scale 0–80 °C; differential by-pass kit with 2–6,5 m w.g. setting (provided as standard in 18B.N and 18B.1.N series, optional in 17B.N and 17B.1.N series). High-efficiency pump Grundfos UPM3 Auto 25-70 130 (Wilco Para 25-130/7-50/SC-12, 3 constant speed Grundfos UPSO 25-65 130 (Extra EU)), supply 230 V (50-60 Hz). Working temperature range 5–90 °C; maximum working pressure 10 bar.

Series 07B.N

Differential by-pass kit. Threaded connections 15 mm - G 3/4 M - Rp 3/4. The kit is composed of: adjustable Tee fitting in brass for differential by-pass kit connection, differential by-pass valve with 2–6,5 m w.g. setting, by-pass pipe in chrome-plated copper with compression ends. Maximum working temperature 90 °C; maximum working pressure 10 bar. Connection centre distance to group 211 mm.

