

DIRECT DISTRIBUTION GROUP DN 20

Description



Preassembled pump group for direct distribution or circulation. Allows the circulation of the thermal fluid, coming from the primary circuit, without performing any thermal regulation. It is used when the same flow temperature of the primary circuit is requested by the user in heating systems. The group is composed of a pump, flow/return shut-off valves, shut-off valve at the pump inlet, flow/return temperature gauges, anti-thermosiphon check valve, thermal insulation. In this group, the differential by-pass can be installed only externally. The group is reversible (flow line can be exchanged with the return line). Male and female thread on system side connections.

BAFA
LIST

Range of products

Direct distribution group	01G	XXX	XX	X
Male and female thread on system side connections G 1 M+G 3/4 F		020		
Without accessories			00	
Without pump				X
Pump Wilo Para 15-130/7-50/SC-9				P
Pump Grundfos UPM3 AUTO 15-70 130				L
Pump Grundfos UPSO 15-65 130 (Extra EU)				F

on request

Features

Working temperature range: **5–90 °C**
 Max working pressure: **10 bar**
 Female connections: **EN 10226-1**
 Male connections: **ISO 228-1**
 Connection centre distance: **90 mm**
 Pump: **Wilo Para 15-130/7-50/SC-9**
 Grundfos UPM3 AUTO 15-70 130
 Grundfos UPSO 15-65 130 (Extra EU)
 Suitable fluids: **water, glycol solutions (max 30%)**
 Temperature gauge scale: **0–120 °C**

Pump

- Body: **cast iron**
- Electric supply: **230 V-50/60 Hz**
- Protection class:
 - Wilo Para: **IPx4D**
 - Grundfos UPM3: **IP 44**
 - Grundfos UPSO (Extra EU): **IP 44**
- Centre distance: **130 mm**
- Connections: **G 1 M (ISO 228-1)**

Insulation shell

- Body: **EPP**
- Density: **60 kg/m³**
- Working temperature range: **-5–120 °C**
- Thermal conductivity: **0,04 W/(m·K)**

Materials

Ball valves

- Body: **brass EN12165 CW617N**
- Gaskets: **PTFE, EPDM, Viton**

Extension: **galvanized steel**

Check valve insert

- Body and obturator: **POM**
- Gasket: **NBR**

DIRECT DISTRIBUTION GROUP DN 20

Components

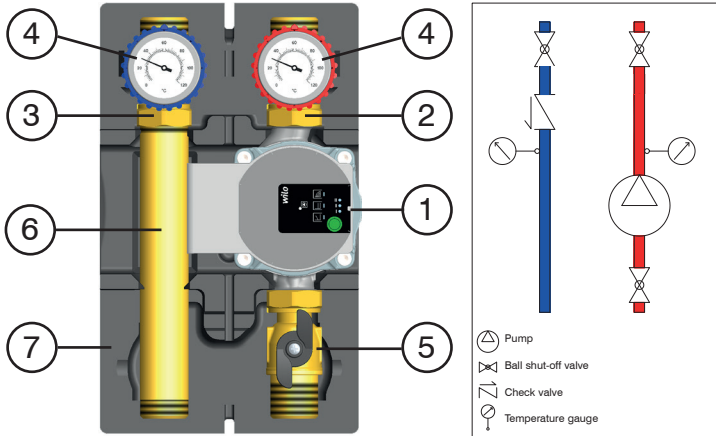

01G.DN20		
1	Pump	Wilo Para, Grundfos UPM3 AUTO, Grundfos UPSO (Extra EU)
2	Ball shut-off valve	
3	Ball shut-off valve with check valve	
4	Temperature gauge	
5	Ball shut-off valve	
6	Extension	
7	Insulation	

Dimensions

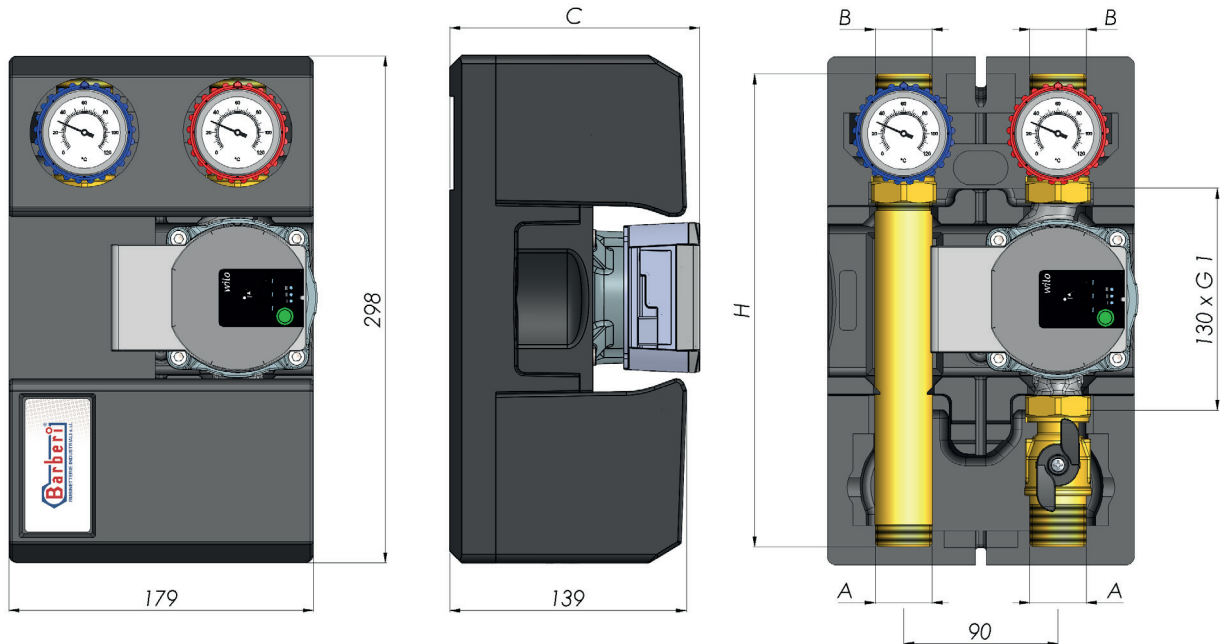

Code	P [bar]	A	B	C [mm]	H [mm]	Pump	Weight [kg]	N. P/B	N. P/C
01G 020 00X	10	G 1 M	G 1 M+G 3/4 F	-	277	Without pump	1,9	-	1
01G 020 00P	10	G 1 M	G 1 M+G 3/4 F	147	277	Wilo Para 15-130/7-50/SC-9	3,4	-	1
01G 020 00L	10	G 1 M	G 1 M+G 3/4 F	145	277	Grundfos UPM3 AUTO 15-70 130	3,6	-	1
01G 020 00F	10	G 1 M	G 1 M+G 3/4 F	156	277	Grundfos UPSO 15-65 130 (Extra EU)	4,4	-	1

N. P/B: number of pieces in box - N. P/C: number of pieces in carton
 Other pump types should be evaluated

DIRECT DISTRIBUTION GROUP DN 20

Diagrams

Group sizing (operation for specialized/authorized technical personnel).

Step 1: head losses of the group without pump. Enter on the x-axis of the first diagram with the design flow rate value. Cross the curve of the group and read the corresponding head losses of the group (without pump) on the y-axis.

Step 2: available head of the pump. With the same design flow rate value, enter on the x-axis of the selected pump diagram ("Head of pump"). Cross the curve of the selected working mode (Constant speed, Proportional pressure, Constant pressure) and read the corresponding available head of the pump on the y-axis.

Step 3: pump validation. Calculate the difference between the available head of the pump and the head losses of the group without pump. The remaining pump head should be higher than the head losses of the rest of the system: if so, the selected pump is suitable to supply water to the rest of the system, otherwise a different pump working mode or pump size or different group size or a system resizing could be necessary.

Hydraulic characteristics: head losses of the direct distribution group without pump

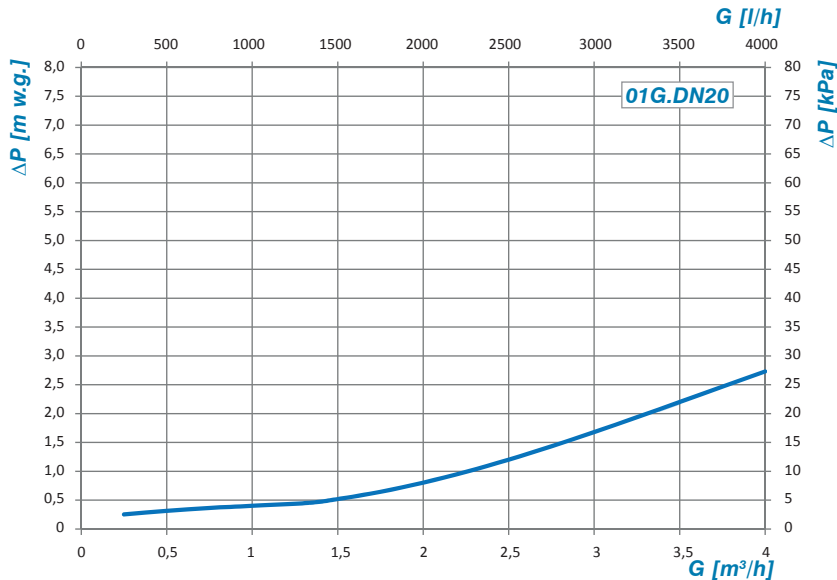

Head and power consumption of the pumps

Head of pump Wilo Para 15-130/7-50/SC-9

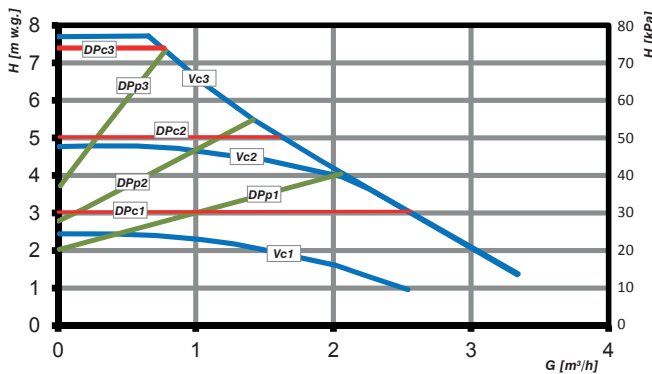

Vc: Constant speed
 DPp: Proportional pressure
 DPc: Constant pressure

Power of pump Wilo Para 15-130/7-50/SC-9

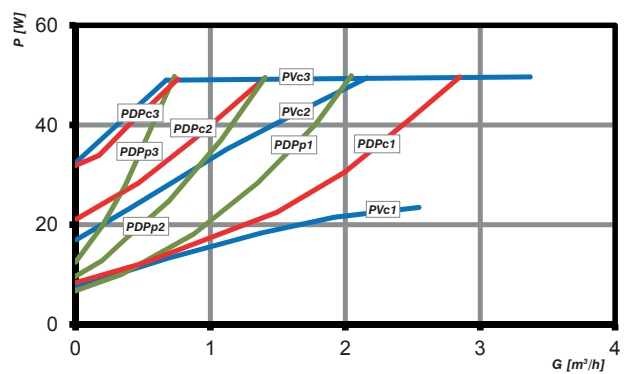

PVc: Power consumption at constant speed
 PDPp: Power consumption at proportional pressure
 PDPc: Power consumption at constant pressure

DIRECT DISTRIBUTION GROUP DN 20

Head of pump Grundfos UPM3 AUTO 15-70 130

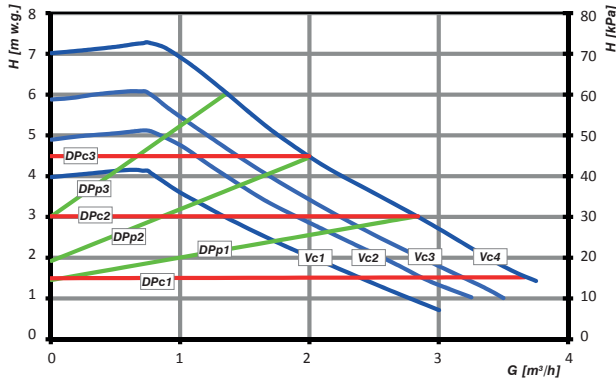

Vc: Constant speed
 DPp: Proportional pressure
 DPc: Constant pressure

Power of pump Grundfos UPM3 AUTO 15-70 130

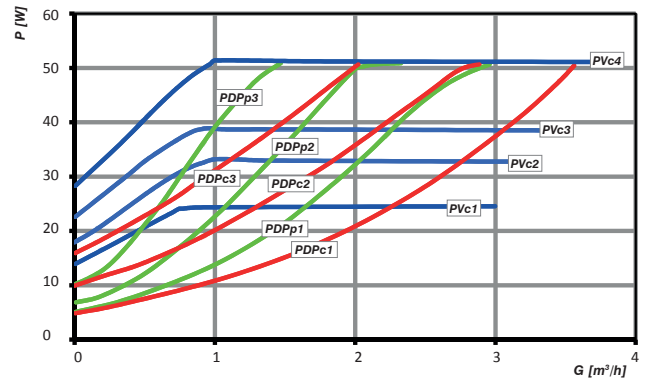

Pvc: Power consumption at constant speed
 PDPp: Power consumption at proportional pressure
 PDPc: Power consumption at constant pressure

Head of pump Grundfos UPSO 15-65 130 (Extra EU)

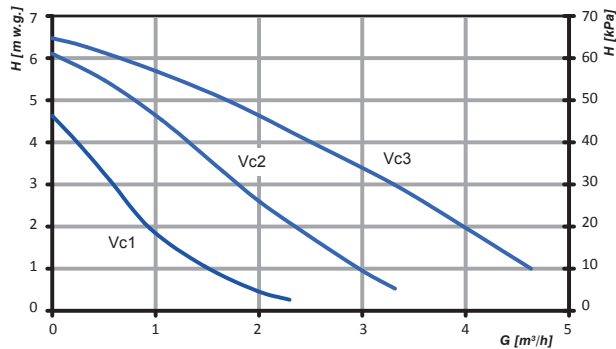

Vc: Constant speed

Power of pump Grundfos UPSO 15-65 130 (Extra EU)

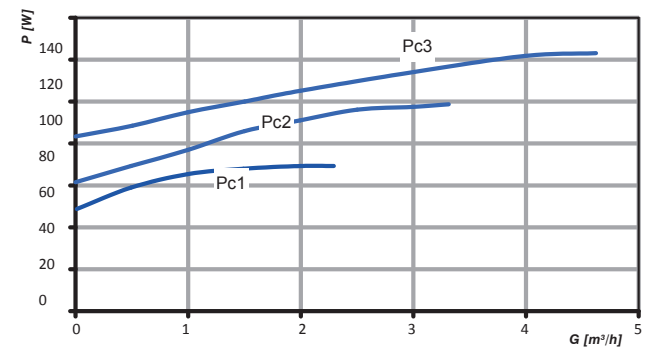

Pvc: Power consumption

Features

The direct distribution group consists of:

- Front insulation shell (1) upper and lower part,
- Rear insulation shell (2),
- Central front insulation shell (3),
- Flow line (4) including 2 ball shut-off valves, temperature gauge and pump
- Return line (5) including ball shut-off valve, check valve, temperature gauge and extension.

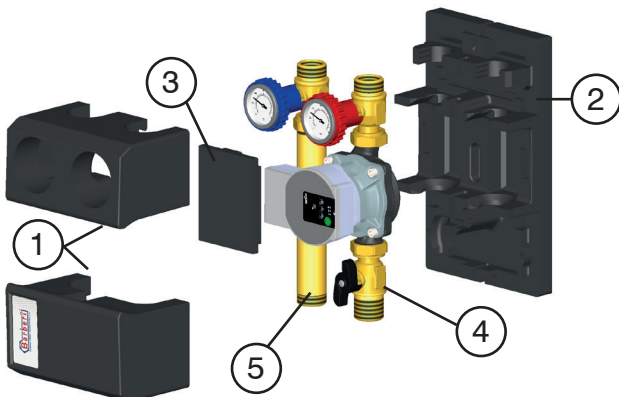

Advantages

Energy saving: the front (1) and rear shells (2) help the thermal insulation of the group and allow energy saving.

Pump protective shell (3): maintains the thermal insulation and avoids overheating of the pump electronic part. In this way the risk of damage is reduced.

Fast assembling insulation: the rear insulation shell (2) remains hanging to the group also after removing the front shell parts (1). This allows a fast and easy reassembling of the insulation after completing the work.

Compact installation: 90 mm centre distance with 130 mm pump connections makes the installation very compact.

Frontal devices: all devices, such as the pump menu, temperature gauges, shut-off valves and, in mixed groups, the thermostatic valve and actuator, are frontal. This allows fast regulation and functional check, in particular for the installation of several groups very close to one another.

Check valve with override: the groups are factory equipped with a check valve on the return line, placed within the monobloc with blue knob. By rotating at 45° the blue knob, it is possible to override the check valve function, thus allowing the water passage in two directions and making the filling phase of the system much faster. The mixed groups have the

DIRECT DISTRIBUTION GROUP DN 20

T-fitting, connecting the mixing valve, suitable for the insertion of a further removable check valve insert.

Versatility of the wall mounting bracket: the universal bracket 42D.DN20 (accessory) makes it possible to install the group with flow upward, downward or with the group laying on a side. Pay however the maximum attention to correctly fix the group to the wall when installed laying on a side. The bracket, in addition to the traditional two side holes, has a third central hole to screw the group to the wall with one only central anchor, after making a specific hole in the insulation shell. This allows to fix the whole group to the wall already hanging to the bracket.

Transformability: in case of need, the groups are easily transformable from one version to another (eg. from direct distribution group to thermostatic, mixed and vice versa) as they share the vast majority of components.

Identical actuators for all DN: the motorized groups DN 20 can be combined with the same actuators of the DN 25 and DN 32 ranges, allowing a reduction of the models to be purchased and consequently of the warehouse.

Pump range: the groups are available with three different pump models. For the use of other models and/or manufacturers, it is advisable to contact Barberi for verification.

Quick pump replacement: the circulators can be quickly replaced without completely removing the rear insulation.

Flat gaskets: the various components of the groups are connected to each other by means of flat seal fittings. This makes the installation faster by avoiding the use of hemp or other sealants.

Cable glands: the insulation of the groups is equipped with cable glands pointing upward and downward to allow the cables to be laid safely and tidy.

Accessibility and maneuverability of the nuts: the insulation is designed in such a way as to leave the space necessary to maneuver all the nuts, with a suitable hexagonal key, without having to remove it. This is an advantage especially in the wall installation where the insulation is laying against the wall or when pipes pass behind the insulation.

The nuts are supplied loosened to facilitate the group reversal on the installation field. Fully screw the nuts before installing the group.

Installation

The mounting options of the group are:

- Wall installation
- Manifold installation

The group can be installed on manifolds with integrated hydraulic separator, on standard manifolds with independent hydraulic separator, on manifolds connected to a storage.

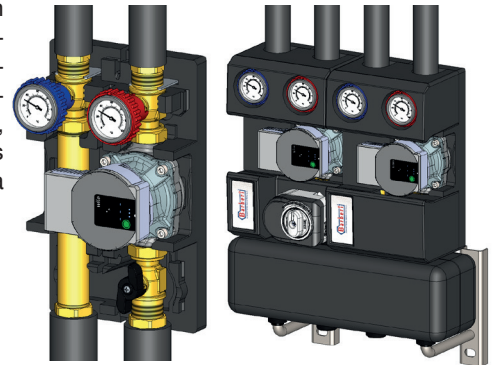

Group position

The group can be installed in one of the ways shown in the picture, with the pump rotation axis always horizontal.

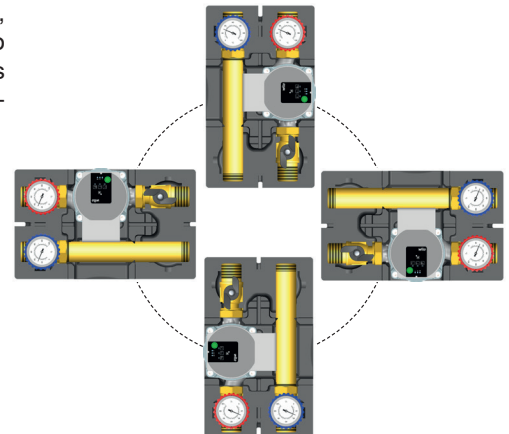

Group reversibility

The group is factory set with pump on the RH side and flow upwards (or, by rotating it, pump on the LH side and flow downwards). The reversibility is allowed on the installation field simply by exchanging the flow line with the return one. Warning: due to the presence of a check valve, keep the ball shut-off valve with red knob on the pump line and the blue knob on the return. For some pump models, it is necessary to rotate the electronic part to place it within the insulation.

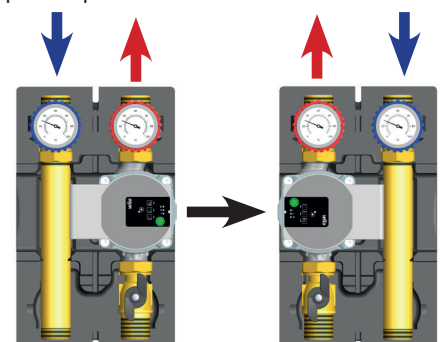

DIRECT DISTRIBUTION GROUP DN 20

System diagrams

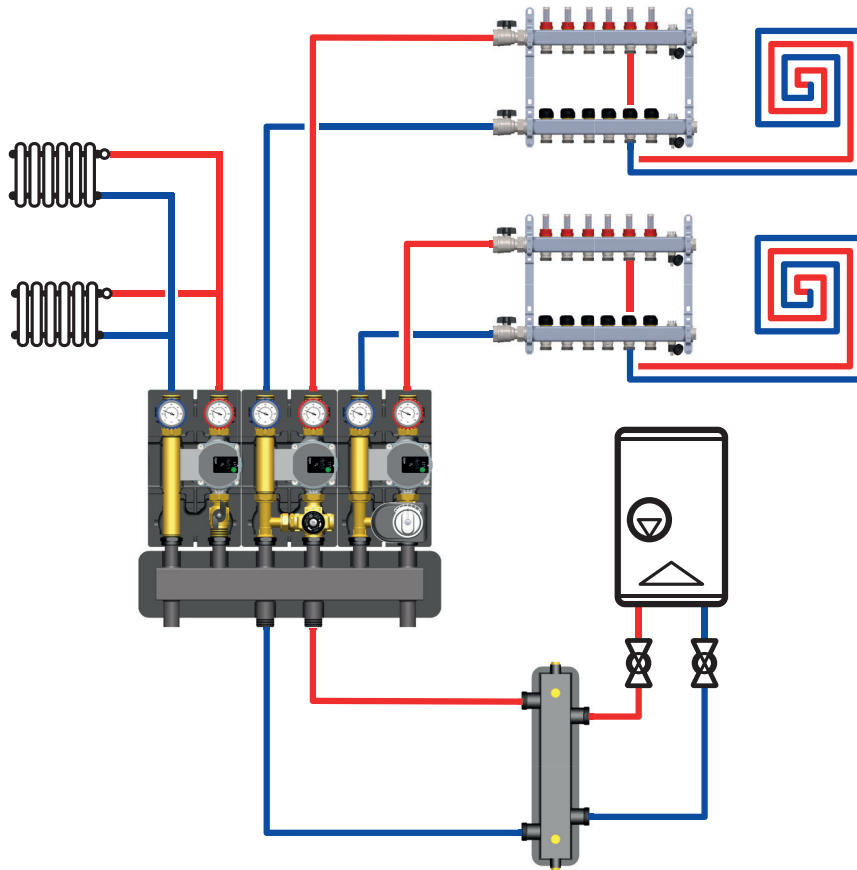

Accessories

42D.DN20

Bracket for wall mounting of the distribution and regulating group, with screws and anchors

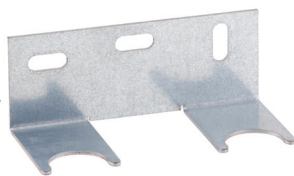

Hole centre distance: **45 mm**
 Hole diameter: **8 mm**

Code		
42D 020 Z00 I	1	25

Specifications

Series 01G.DN20

Direct distribution group with G 1 M connections with plane gaskets to the primary circuit and G 1 M+G 3/4 F double thread connection to the secondary circuit. Centre distance between flow and return connections 90 mm. Height of flow and return lines 277 mm. Dimensions of the group with shell 179x298x139 mm (Width x Height x Depth). The group is composed of: ball shut-off valves in brass on the flow and return of the secondary circuit, POM check valve on the return line, ball shut-off valve in brass on the flow line of the primary circuit, flow and return temperature gauges with 0–120 °C scale. High-efficiency pump Wilo Para 15-130/7-50/SC-9 (Grundfos UPM3 AUTO 15-70 130, 3 constant speed pump Grundfos UPSO 15-65 130 (Extra EU)), electric supply 230 V (50 Hz). Insulation shell in EPP. Working temperature range 5–90 °C. Maximum working pressure 10 bar.