

ROTARY MIXING VALVE WITH BY-PASS



Description

Barberi[®] mixing valves with or without actuator are devices that allow the mixing between two fluids (e.g. warm and cold water) to get the desired temperature. They could be used in heating and refreshing installations, in heating plants, in heat generators (hang-wall boilers, wood boilers, heating pumps), in distribution groups.

The mixing between fluids is obtained through a shaped rotor that regulates the fluid's passage. The mixing valves can be used in manual mode or with electrical actuator. Features of these valves are the running nut for pump connection, the male connection to the manifold and the bypass on the way back. The by pass on the return will improve the regulation especially when electrical actuators are used.

Article range

art. 41D 3-ways rotary mixing valve with by-pass / pump connection

Technical features

Min - max. acceptable temperature(peaks):
-20 °C (see suitable fluids) – 130 °C

Min - max. working temperature:
0 °C (no frost) – 110 °C

Max working pressure: **10 bar**

Rotor's torque: **under 5 Nm**

Rotor's rotation's angle: **90°**

Leakage: **<0,1%**

Suitable fluids: **water for heating installation,
glycolated water(max 50%)**

Installation connection:

M threaded connections UNI ISO 228-1

Materials

Valve's body: **brass UNI EN 12165 CW617N**

Flanges: **brass UNI EN 12164 CW614N**

Rotor: **brass UNI EN 12165 CW617N**

Washers: **EPDM**

Numbered plate: **PVC**

Handle: **ABS**

Working way

Working way as mixing valve

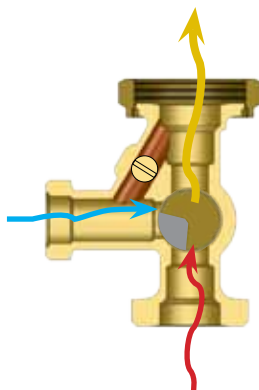

**Mix with closed
By-pass**

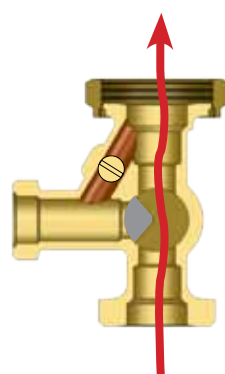

**Only hot
with closed By-pass**

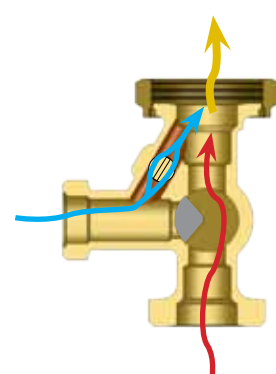

**Only hot
with opened By-pass**

ROTARY MIXING VALVE WITH BY-PASS

Working way as diverting valve

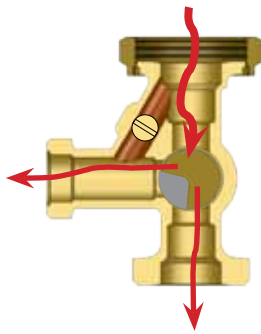

Deviation with closed By-pass

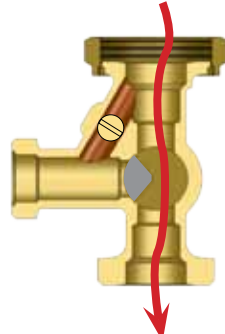

Only straight way with closed By-pass

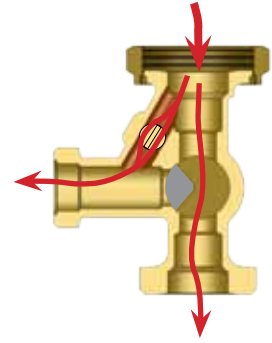

Only straight way with opened By-pass

Rotary mixing valve sets the fluid temperature of supply. This setting is obtained by mixing a warm fluid at higher temperature with a warm fluid at a lower temperature within the mixing chamber. The mixing is done by a shaped rotor which allows the closure or the opening of fluids' passage bores.

The three ways valves can be used as mixing valves (by setting the installation's temperature before the valve) or as diverting valve (by setting the installation's flow rate before the valve).

Dimensions

art. 41D

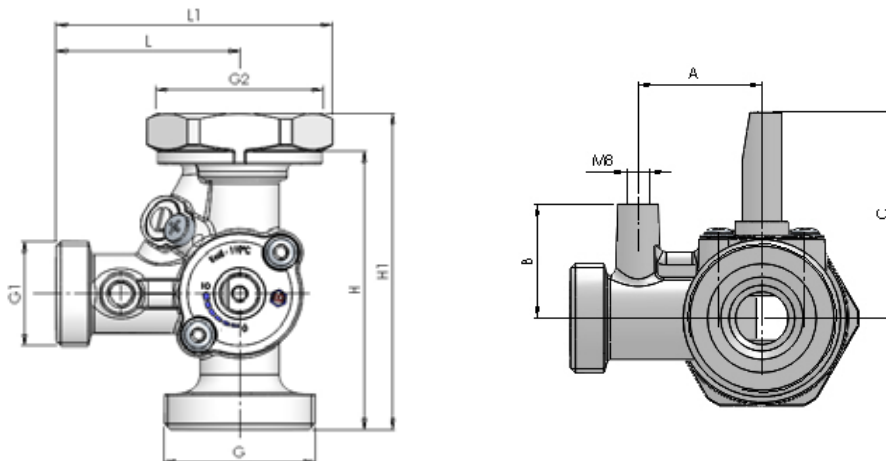

Code	P [bar]	KV [m ³ /h]	G	G1	G2	L	L1	H	H1	A	B	C	weight	N. P/B	N. P/C
41D 040 000 C	10	6	1"1/2 M	1" M	1"1/2 F	58	87,5	90	100	37,5	34,5	62,5	805	1	10
41D 040 000 I	10	10	1"1/2 M	1" M	1"1/2 F	58	87,5	90	100	37,5	34,5	62,5	805	1	10
41D 050 000 G	10	18	2" M	1"1/4 M	2" F	58	94,6	98	109	37,5	37	65	1160	1	10

Weight (grams) - N. P/B: number of pieces in box, plastic bag - N. P/C: number of pieces in carton

ROTARY MIXING VALVE WITH BY-PASS

Installation

Before installing a mixing valve please verify system's working conditions, such as pressure and temperature, to be sure that they are within the working conditions of the valve.

The system, where the valve will be installed, shall be cleaned and flushed before installing the valve.

We suggest also to install suitable filters at the system. Without a suitable cleaning of the system the correct working of the valve can be damaged and the manufacturer guarantee upon the product could fail. If the valve will be used with hard water, we suggest to install devices to soften water before the valve's inlet.

It is important that the valve is free from obstacles for its duly maintenance.

Positioning

The mixing valve can be installed in positions as in fig.3.

Fig. 3

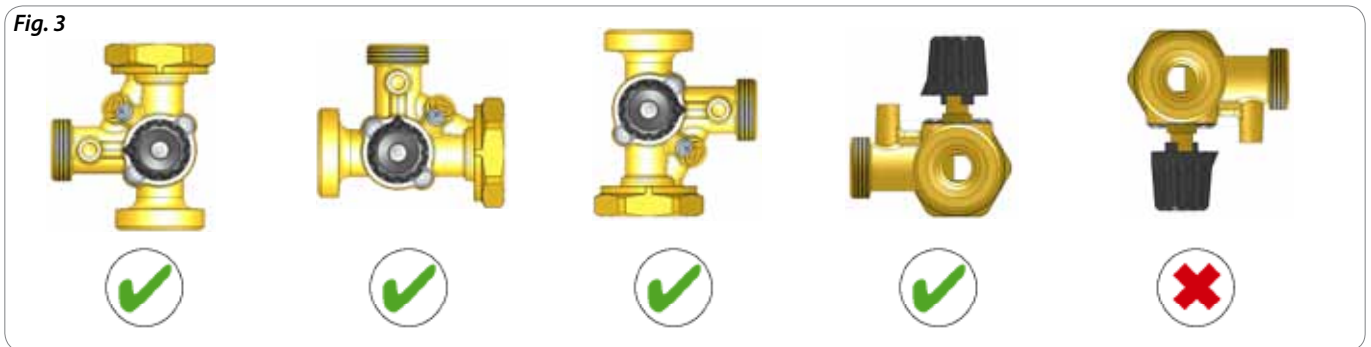

Adjustment of the mixing valve

The mixing valve allows the setting of temperature of delivery through the mixing of hot and cold thermal fluid. The regulation is obtained by regulating manually the valve with the handle supply or through the actuator. The mixing valve that is supplied inside the group has a by-pass system to be regulated. This by-pass is helpful for delivery temperature regulation when the mixing valve is motorized and controlled by a regulator. It's possible to regulate the supply temperature when the valve has the return way totally closed (highest demand from the consumption). By this way the temperature regulation from the controller, will cover a rotation of 90°, avoiding instabilities of temperature, change of rotation of the actuator and dangerous peaks of temperature. ATTENTION: in case of high difference of temperature between the boiler and the consumption it's possible not to achieve the consumption temperature, even if the by-pass is completely open.

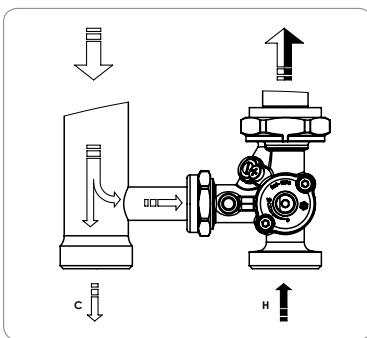

In order to do an accurate temperature setting, it's important to switch on the heat generator at the supply temperature following the project specifications and to bring the system according to scheme. By this way the adjustment of the valve will be maintained as accurate as possible.

1. Assemble the handle (1) with the screw supplied with the group.

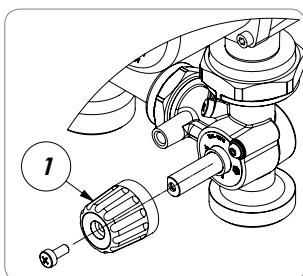

2. Rotate the handle (1) in the position indicated (arrow on nr 10). In this position there is no mix

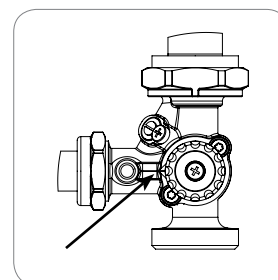

ROTARY MIXING VALVE WITH BY-PASS

3. Switch on the pump
4. Loosen the screw (2) of the by-pass
5. Regulate the screw (3) of the by-pass to get the correct temperature. Consider that by-pass on the left is totally closed, the one in the centre is totally open. Close the screw (2)

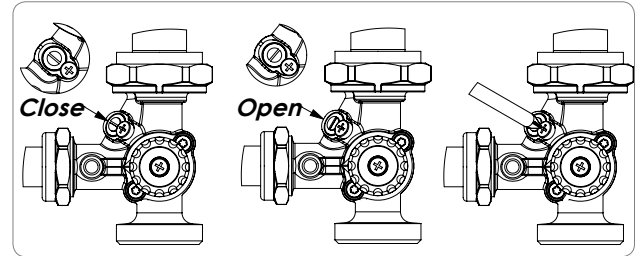
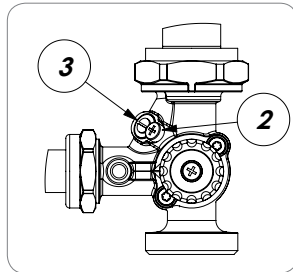

6. In case the by-pass regulation is not enough, bring the handle (1) in the position to reach the temperature of the project. By this way if the handle was tampered, the by-pass would limit the supply temperature.

Installation of actuator

The actuator for distribution group is supplied with the components you can see in the picture. Actuator (1), Graduated ring (2), Mixing adapter (3), Actuator stop screw (4), clamping screw (5). Follow these steps for the installation on the mixing valve.

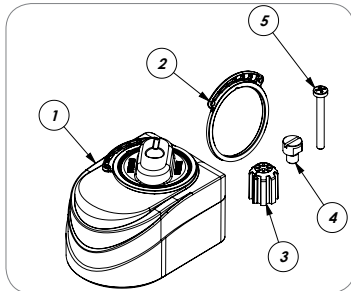

1. Look at the graduated ring (2) for the percentage of hot water. Turn the ring as in the picture on the right.

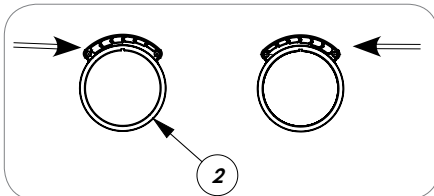

2. Insert the ring (2) inside the guide of the actuator (1)

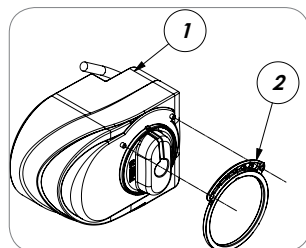

3. By pressing and rotating clockwise, turn the handle until the end and stop it.

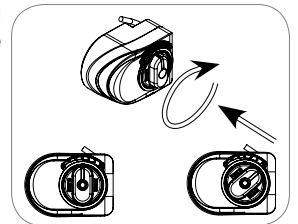

4. Insert the adaptor (3) and screw the actuator stop screw (4).

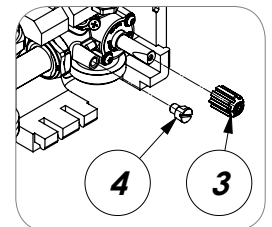

5. Look at the mark on the adapter.

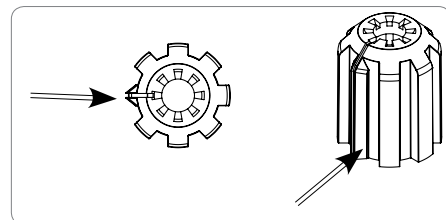

ROTARY MIXING VALVE WITH BY-PASS

6. Turn the mark of the adapter (3) until reaching position no. 10 on the mixing valve.

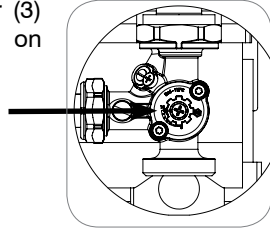

8. Connect the wires of the actuator to the right regulator for climate setting based on outside temperature or for setting the supply temperature based on room temperature.

7. Insert the actuator (1) as in the picture and close everything with the clamping screw. By this way the handle of the actuator is positioned to achieve the maximum flow rate on supply and no flow rate on return.

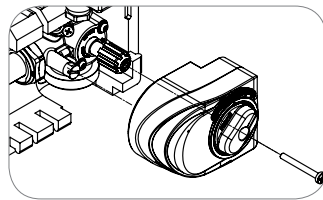

Diagrams

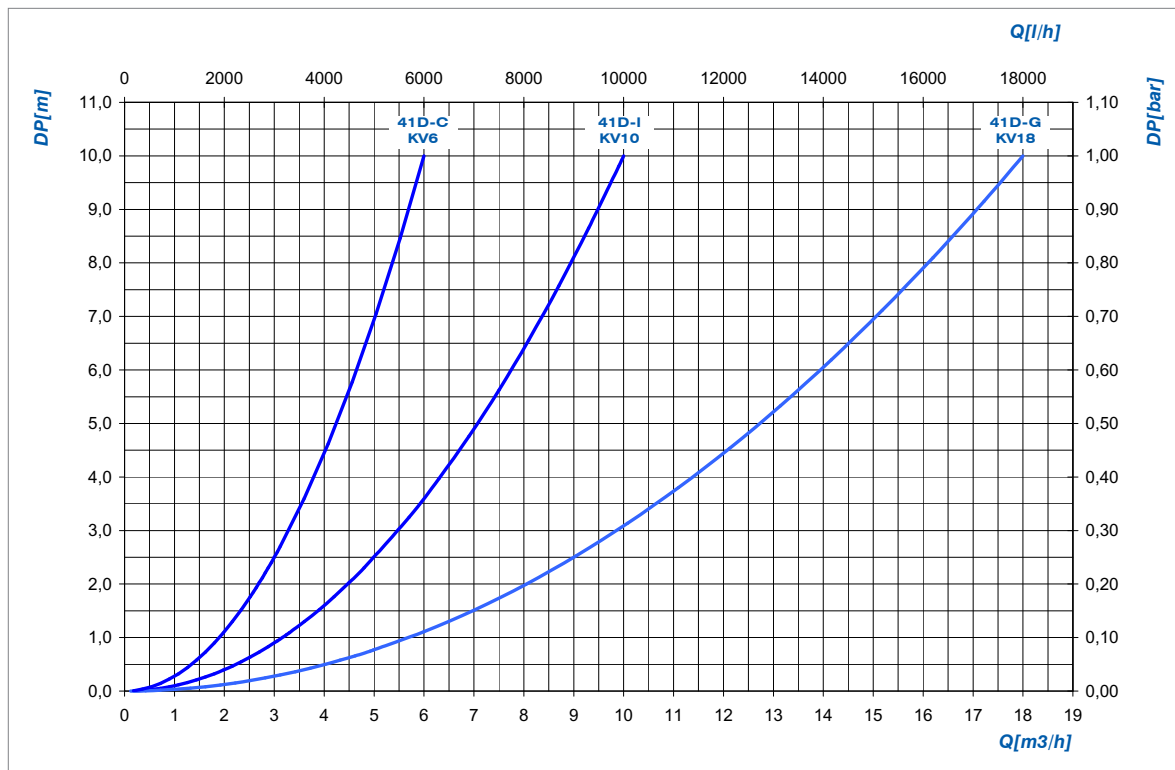

ROTARY MIXING VALVE WITH BY-PASS

Specifications

The specification's text refers to a specific article reference. Each version of the product obliges the engineer to modify the specification's text

Art.Ref. 41D 040 000 C

3ways rotary mixing valve KV6 with by-pass, handle for manual setting and possibility to assemble an actuator (stroke 90°). Threaded connections G 1"1/2M, G 1"M, running nut G 1"1/2F, 90mm hit's distance. Body in brass material UNI EN 12165 CW617N. Closing flange UNI EN 12164 CW614N. EPDM washers. PVC numbered plate. ABS handle. Max working pressure 10bar. Max working temperature 110°C. Suitable fluids water or glycoled water (max.50%)

Art.Ref. 41D 040 000 I

3ways rotary mixing valve KV10 with by-pass, handle for manual setting and possibility to assemble an actuator (stroke 90°). Threaded connections G 1"1/2M, G 1"M, running nut G 1"1/2F, 90mm hit's distance. Body in brass material UNI EN 12165 CW617N. Closing flange UNI EN 12164 CW614N. EPDM washers. PVC numbered plate. ABS handle. Max working pressure 10bar. Max working temperature 110°C. Suitable fluids water or glycoled water (max.50%)

Art.Ref. 41D 050 000 G

3ways rotary mixing valve KV6 with by-pass, handle for manual setting and possibility to assemble an actuator (stroke 90°). Threaded connections G 2"M, G 1"1/4M, running nut G 2"F, 98mm hit's distance. Body in brass material UNI EN 12165 CW617N. Closing flange UNI EN 12164 CW614N. EPDM washers. PVC numbered plate. ABS handle. Max working pressure 10bar. Max working temperature 110°C. Suitable fluids water or glycoled water (max.50%)

Accessories

Art. M03

Compact actuator for mixing valves, running angle 90°, for 3 points and on/off setting. Comes complete with blocking screw, mixing valve adaptors, anti-rotation pin, 1,5m integrated cable.



Torque: 10 Nm
Running time: 60 s, 120 s
Power supply: 230 V, 24 V
Frequency: 50 Hz

code	V	control	running time [s]	N° poles	Torque [Nm]
M030101DAB	230 V	3 pt.	120	3	10
M030101GAB	230 V	3 pt.	120	6	10
M030101DBB	230 V	3 pt.	60	3	10
M030101GBB	230 V	3 pt.	60	6	10
M030101AAB	230 V	on/off	120	3	10
M030101HAB	230 V	on/off	120	6	10
M030101ABB	230 V	on/off	60	3	10
M030101HBB	230 V	on/off	60	6	10
M030102DAB	24 V	3 pt.	120	3	10
M030102GAB	24 V	3 pt.	120	6	10
M030102DBB	24 V	3 pt.	60	3	10
M030102GBB	24 V	3 pt.	60	6	10
M030102AAB	24 V	on/off	120	3	10
M030102ABB	24 V	on/off	60	3	10

ROTARY MIXING VALVE WITH BY-PASS

Art. P27T

Actuator for mixing valves, running angle 90°, with integrated probe and temperature setting device. Comes complete with blocking screw, mixing valve adaptors, anti-rotation pin, NTC probe (1m cable), probe's carrying bracers fitting, integrated European electrical wire connection, 2m integrated cable.



Torque: 10 Nm
Running time: 135 s
Power supply: 230 V
Frequency: 50 Hz

code	V	control	running time [s]	N° poles	Torque [Nm]
P27230010T	230 V	3 pt.	135	2	10

Art. M04

Actuator for mixing valves, running angle 90°, for proportional setting. Comes complete with blocking screw, mixing valve adaptor, anti-rotation pin, 1,95m integrated cable



Running time: 60 s, 90 s, 120 s
Power supply: 24 V
Frequency: 50 Hz
Control: 0(2)-10V
Feedback: 0-10V/0-40mA

code	V	control	running time [s]	N° poles	Torque [Nm]
M040103MAB	230 V	0(2) - 10 V	60 - 90 - 120	3	5

Art. 45D

T-joint

Max working temperature: 140 °C



code	size
45D 040 000	G 1"½ fit. - G 1"½ M - G 1" fit.
45D 050 000	G 2" fit. - G 2" M - G 1"¼ fit.

ROTARY MIXING VALVE WITH BY-PASS

Related articles

Art. 07G/09G-DN25

Distribution group with actuated mixing valve - reversible - DN25

Max inlet temperature: 90 °C

Allowed fluids: water, mix water and glycol(max 30%)



code	size	KV mix	pump	P [bar]
07G 025 00X	G 1" F - G 1½" M	6	without pump	10
07G 025 00C	G 1" F - G 1½" M	6	Grundfos UPSO 25-65	10
07G 025 00G	G 1" F - G 1½" M	6	Grundfos ALPHA2L 25-60	10
▶ 07G 025 00D	G 1" F - G 1½" M	6	Grundfos ALPHA2 25-60	10
07G 025 00L	G 1" F - G 1½" M	6	Wilo YONOS PARA 25-6	10
09G 025 00X	G 1" F - G 1½" M	10	without pump	10
09G 025 00C	G 1" F - G 1½" M	10	Grundfos UPSO 25-65	10
09G 025 00G	G 1" F - G 1½" M	10	Grundfos ALPHA2L 25-60	10
▶ 09G 025 00D	G 1" F - G 1½" M	10	Grundfos ALPHA2 25-60	10
09G 025 00L	G 1" F - G 1½" M	10	Wilo YONOS PARA 25-6	10

Art. 07G-DN32

Distribution group with actuated mixing valve - reversible - DN32

Max inlet temperature: 90 °C

Allowed fluids: water, mix water and glycol(max 30%)



code	size	KV mix	pump	P [bar]
07G 032 00X	G 1¼" F - G 2" M	18	senza pompa	10
07G 032 00E	G 1¼" F - G 2" M	18	Grundfos ALPHA2L 32-60	10
07G 032 00T	G 1¼" F - G 2" M	18	Grundfos UPSO 32-65	10
▶ 07G 032 00F	G 1¼" F - G 2" M	18	Grundfos UPML 32-95	10